



BHADRAK ENGINEERING SCHOOL & TECHNOLOGY
(BEST), ASURALI, BHADRAK

Manufacturing Technology (Th- 02)

(As per the 2020-21 syllabus of the SCTE&VT,
Bhubaneswar, Odisha)



Fourth Semester
Mechanical Engg.

Prepared By: *Er P K Mohanty*

CHAPTER-01

TOOL MATERIALS

Introduction:-

- The effect of tool material on tool life which indicates that higher cutting speed is not the only criteria considered for removing large volume of metal.
- An ideal tool would remove the same amount of metal per cutting edge at any speed.
- Physical and chemical properties of work materials influence tool life by affecting from stability and rate of wear of tool.

1.1 Composition of various tool materials:-

1. Carbon steel:-

- Carbon steel contains carbon in amounts ranging from 0.08 to 1.5 percent.
- Due to low heat and wear resistance, they may only used in the manufacture of tools operating at low cutting speeds and of hand operated tools.
- But they are comparatively cheap, easy to Forge, and simple to harden.

2. Cemented carbide:-

- The basic ingredients of most cemented carbide is tungsten carbide which is extremely hard.
- The properties of cemented carbides are , they are very high heat and wear resistance.
- It can withstand to a temperature of 1000 C.
- Cemented carbides are designed for machining of brittle materials such as cast iron, bronze etc. and also used for nonferrous metal, alloys and various types of steels.
- A typical analysis of a carbide suitable for steel machining is 82% tungsten carbide, 10% titanium carbide and 8% cobalt.

3. Ceramics:-

- Ceramic tools are made by composing aluminum oxide powder.
- Ceramic tool materials are in the form of tips that are to be clamped on metal shanks.
- Other materials used to produce ceramic tools are silicon carbide, boron carbide and titanium boride.
- These tools have very low heat conductivity and extremely high compressive strength.
- It can withstand temperatures up to 1200 C.

4. High speed steel:-

- It is generally used for low and medium cutting speed.
- It is used for drilling, tapping, hobbing, milling, turning etc.

- There are three general types of High speed steels –High tungsten, high molybdenum and high cobalt.
- Tungsten in H.S.S provides hot hardness, molybdenum maintains sharpness of cutting edges, cobalt improves hot hardness and makes the cutting tool more wear resistant.

It is further classified into three types:-

A. 18-4-1 High speed steel (T-Series):-

This steel Containing 18% tungsten, 4 % chromium and 1 % vanadium.

B. Molybdenum high speed steel (M-series):-

The steel containing 6% molybdenum,6% tungsten,4% chromium and 2% vanadium.

This steel have excellent toughness and cutting ability.

C. Cobalt high speed steel:-

This is sometimes called super high speed steel.

This steel contains 20% tungsten, 4%chromium, 2% vanadium and 12% cobalt.

5. Diamonds:-

- The diamond is the hardest material and can be run at 50 times greater than H.S.S tool, and withstand at a temperature of 1650 C.
- Diamonds are suitable for cutting very hard material such as glass, plastics, ceramics and other abrasive materials and producing fine finishes.

6. Stellites:-

- It is a non ferrous cast alloy composed of cobalt, chromium and tungsten.
- In this tool-
 - Cobalt--40-48%
 - Chromium---30-35%
 - Tungsten----12-19%
- They are used extensively in some non metal cutting application, such as in rubber, plastics etc.

7. Abrasive:-

- Abrasive grains in various forms—loose, bonded into wheels and stone, and embedded in paper etc.
- They are mainly used for grinding harder materials.
- They are two types---
 - A. Aluminum oxide—for grinding high tensile materials.
 - B. Silicon carbide--- for grinding low tensile materials and non ferrous metals.

1.2 Properties of tool material:--

The main properties of a good tool material are—

1. Hot hardness:-

- In metal cutting, heat is generated during the process and hardness is decreases.

- The tool material must be able to maintain its hardness, wear resistance and strength at a high temperature, which ranges nearly 600 C to 1800C.
2. Toughness:-
 - The tool material must be tough enough so that it can work without fracture in impact forces occurs in interrupted cutting operations such as milling, turning etc.
 - It must be able to withstand vibrations occurred during machining.
 3. Wear resistance :-
 - The term wear means loss of material.
 - As tool continues cu, it's cutting edge which is always in touch with the workpiece and lose their material gradually with time.
 - Therefore the tool material must have wear resistance, so that an acceptable tool life is obtained before the tool replaced.
 4. Chemical stability:-
 - Tool material must have chemical stability with respect to the work material, so that any undesirable reactions between tool material and work material are avoided.
 5. Low friction:-
 - Tool material must have low coefficient of friction, so that the heat generated will be lower, and tool life increases
 6. Shock resistance:-
 - Tool material must have high resistant against thermal and mechanical shocks , specially in intermittent cutting in which tool work engages and disengages at regular intervals.

POSSIBLE QUESTIONS

SHORT QUESTIONS

1. write the various tool materials used in cutting tool.
Ans:- carbon steel, cemented carbide, ceramics, high speed steel, diamonds, stellites, abrasive, etc.
2. what are the properties of cutting tool materials?
Ans:- hot hardness, toughness, wear resistance, chemical stability, low friction, shock resistance, etc.

LONG QUESTION

1. Explain the compositions of various tool materials.
2. Explain the properties of tool materials.

CHAPTER—02

CUTTING TOOL

A cutting tool may be used for cutting apart, as with a knife or for removing chips. Parts are produced by removing metal mostly in the form of small chips.

All cutting tools can be decided into two groups-

1. Single point cutting tool
2. Multi point cutting tool

Single point cutting tool:-

Single point cutting tools are used in turning, shaping, planing and similar operations and remove material by means of one cutting edge.

Multi point cutting tool:-

A multi point cutting tool contains more than two main cutting edges that simultaneously engage in cutting action in a pass.

Ex:- hacksaw blade, files, reamer, grinding wheel etc.

2.1 Cutting action of chisel:-

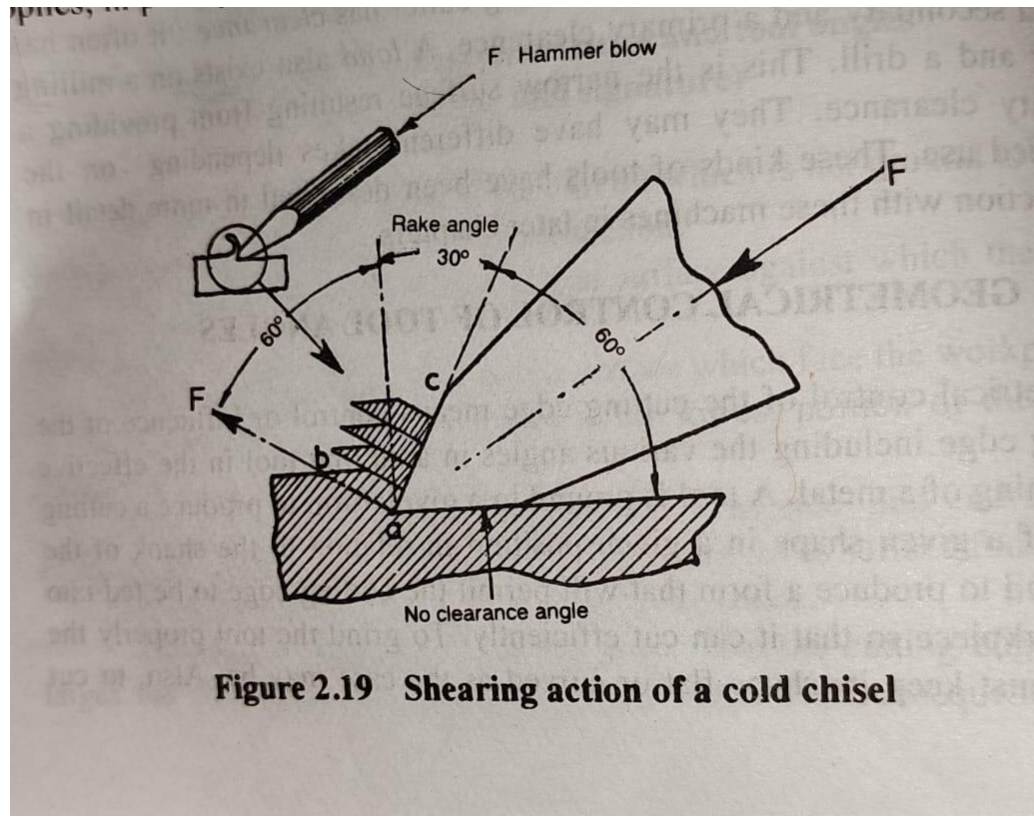

isel:-

- A chisel is a single point tool.
- For mild steel a rake angle of 30° and wedge angle of 60° are recommended.
- The chisel is seen flat on the work and there is no clearance angle.
- This ensures that the depth of cut can be maintained.
- The force of the hammer blow F is transmitted at approximately 90° to the cutting face ac , and this sets up shear stress across the shear plane ab .
- Provided the hammer blow is heavy enough, the metal will shear across the shear plane and move up the face ac as continuous chips.
- The material used in chisels are high carbon steel.
- Chisels are classified into two types-cold chisel, hot chisel.

Cutting action of hacksaw blade:-

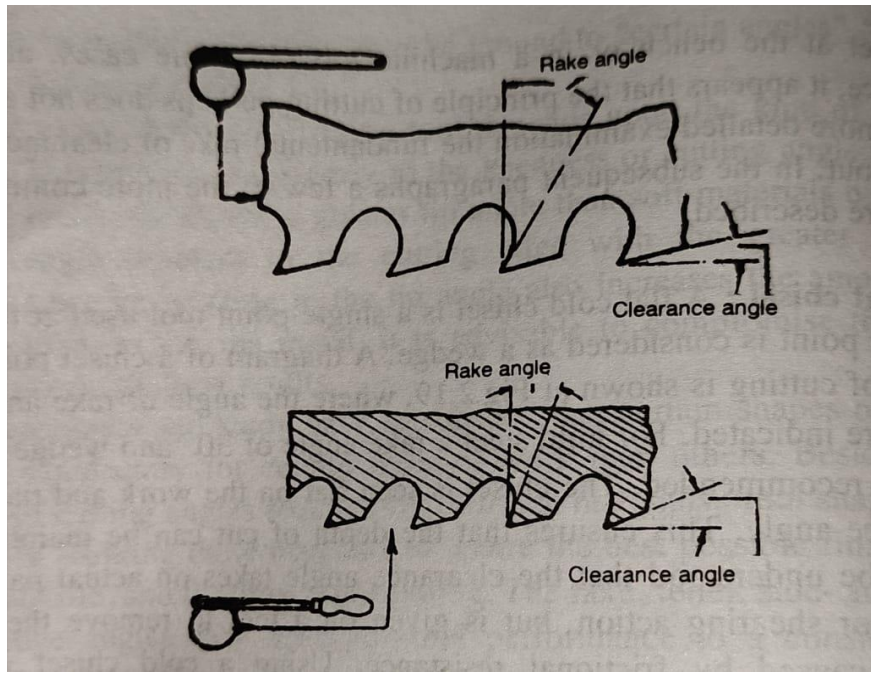

- A hacksaw blade is a multi point cutting tool and has a very large number of wedge like points each with its own rake and clearance angle.
- The rake is necessary but too much rake makes the tooth weak.
- It is also necessary to have clearance angle on these wedge like points.
- Hacksaw blades are made up of high speed steel, low alloy steel, high carbon steel etc.
- The distance between two pin hole is known as blade length. It varies from 250mm to 300mm.
- The distance between the two teeth of a hacksaw blade is known as pitch .
- The number of thread present in between 1inch of hacksaw blade is known as thread per inch(TPI).

Cutting action of dies:-

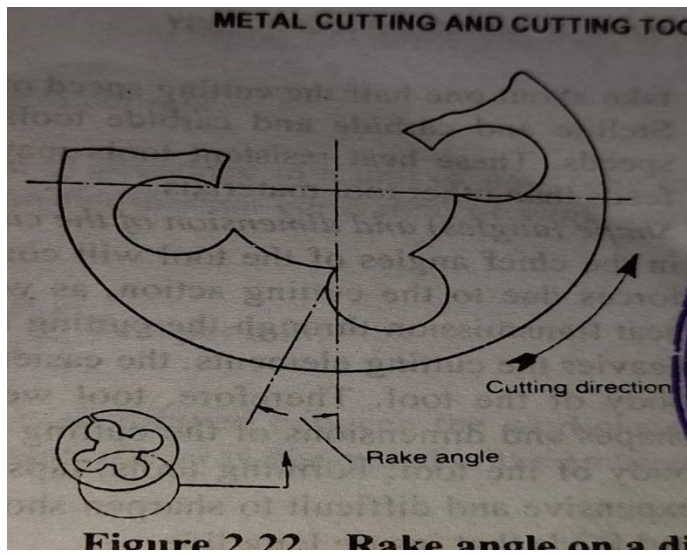

- The dies are used for cutting external threads.
- It is a multi point cutting tool.
- Dies are manufactured from carbon steel or high speed steel.
- The rake angle of a die used for cutting external threads.
- This is obtained by the position of the four holes in a die.

Cutting action of reamer:-

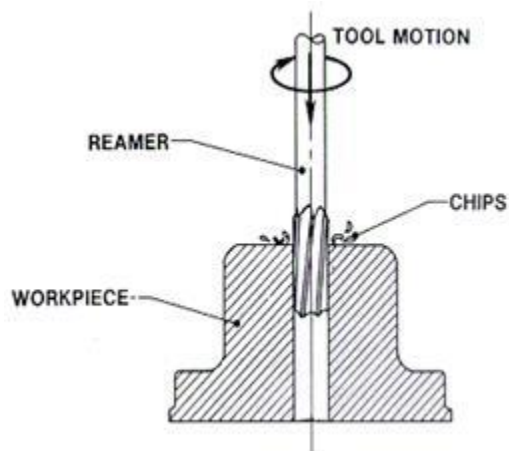

- A reamer is a type of rotary cutting tool used in metal working .it is used to enlarge the hole with a high degree of accuracy.
- There are many different types of reamers and they may be designed for use as a hand tool or as a machine tool.

2.2 Turning tool geometry and purpose of tool angle:-

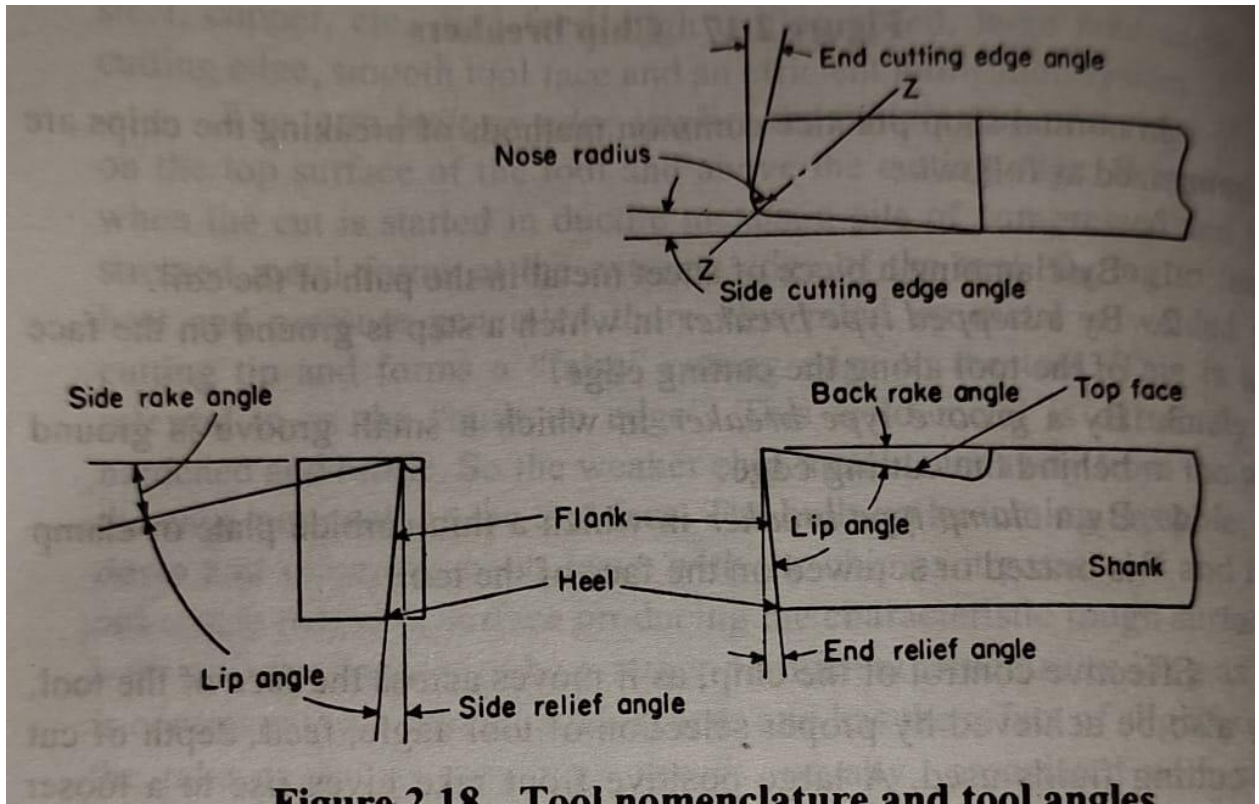

Figure 2.18 Tool nomenclature and tool angles

- The shank is that portion of the tool bit which is not ground to form cutting edges and is rectangular in cross section.
- The face of the cutting tool is that surface against which the chip slides upward.
- The flank of a cutting tool is that surface which face the workpiece.
- The heel of a single point cutting tool is the lowest portion of the side cutting edges.
- The nose of a tool is the conjunction of the side and end-cutting edges. A nose radius increases the tool life and improves the surface finish.
- The base of a tool is the under side of the shank.
- The rake is the slope of the top away from the cutting edge.
- The larger the rake angle, the larger shear angle and subsequently cutting force and power reduced.
- A large rake angle is used to make good surface finish.
- Each tool have a side and back rake angle. Back rake indicates that the plane which forms the face or top of a tool has been ground back at an angle sloping from the nose. Side rake indicates that the plane that form the face or top of a tool has been ground back at an angle sloping from the side cutting edge. Side rake is more important than back rake for turning operation.
- The side relief angle indicates that the plane that forms the flank or side of a tool has been ground back at an angle sloping from the side cutting edge.
- The clearance or end relief angle indicates the nose or end of a tool has been ground back at an angle sloping down from the end cutting edge.

- The end cutting edge angle indicates that the plane which forms the end of a tool has been ground back at an angle sloping from the nose to the side of the shank.
- The side cutting edge angle indicates that the plane which forms the flank or side for a tool has been ground back at an angle to the side of the shank. In the main, chips are removed by this cutting edge.
- The lip or cutting angle is the included angle when the tool has been grounded wedged-shaped.

2.3 Machining process parameters:-

Various machining parameters are—

Speed:-

The cutting speed of a cutting tool may be defined as the speed at which the cutting edge passes over the material. Cutting speed has the greatest influence on tool life. As the cutting speed increases the temperature also rises. It is expressed in meter per minute.

Feed:-

The feed of a cutting tool is the distance travel by the tool in one revolution or one stroke on the workpiece. The tool life is influenced by the feed rate also. It is expressed in mm per revolution, mm per stroke.

Depth of cut:-

It is the total amount of metal removed per pass of the cutting tool. It is expressed in mm. It can vary depending upon the type of tool and work material.

Purpose of cutting fluids:-

Cutting fluids sometimes referred to as lubricants or coolants are liquid and gasses applied to the tool and workpiece to assist in the cutting operations.

1. To cool the tool.
2. To cool the workpiece.
3. To lubricate and reduce friction.
4. To improve surface finish.
5. To protect the finished surface from corrosion.
6. To wash the chips away from the tool.
7. To assist in chips break up into small parts.

2.4 Various types of coolants and lubricants:-

1. Water:-

Water, either plain or containing alkali, salt or water soluble additive but little or no oil or soap are sometimes used only as a coolant. But water alone is in most cases objectionable for its corrosiveness.

2. Soluble oils:-

Soluble oils are emulsions composed of around 80% or more water, soap and mineral oil. The water increases the cooling effect, and the oil provides the best lubricating properties and ensures freedom from rust.

3. Mixed oils:-

This is a combination of straight mineral and straight fatty oil. This blend makes an excellent lubricant and coolant for light machining operations where accuracy and good finish are of prime importance.

4. Straight oil:-

The straight oil may be straight minerals like oils, kerosene, low viscosity petroleum, higher viscosity mineral oils, grease etc.

The straight oil also straight fixed or fatty oils like animal, vegetable or synthetic equivalent, lard oil etc.

They have both cooling and lubricating properties and are used in light machining operations.

5. Chemical compounds:-

These compounds consist mainly of a rust inhibitor, such as sodium nitrate, mixed with a high percentage of water. Chemical compounds have grown in favour as coolants, particularly in grinding and on machined surfaces where formation of rust is to be avoided.

6. Solid lubricants:-

Stick waxes and bar soaps are sometimes used as a convenient means of applying lubrication to the cutting tool.

Properties of cutting fluid:-

- High heat absorption for readily absorbing heat developed.
- Good lubricating qualities to produce low coefficient of friction.
- Stability so as not to oxidize in the air.
- Odorless so as not to produce any bad smell even when heated.
- Neutral so as not to produce react chemically.
- Low viscosity to permit free flow of the liquid.
- Low priced to minimize production cost.
- Non corrosive to the work or the machine.
- Harmless to the skin of the operators.

POSSIBLE QUESTIONS

SHORT QUESTION

1. Define cutting tool.

Ans:- A cutting tool may be used for cutting apart, as with a knife or for removing chips. Parts are produced by removing metal mostly in the form of small chips.

2. cutting tools are classified into how many types?

Ans:- single point cutting tool, multi point cutting tool.

3. What are the coolants and lubricants?

Ans:- water, soluble oil, mixed oil, straight oil, chemical compounds etc.

LONG QUESTION

1. Explain the turning tool geometry with net sketch.

2. Explain the cutting action of hand tools.

3. Write the various types of coolants and lubricants.

CHAPTER-03

LATHE MACHINE

Introduction:-

Lathe is a machine tool on which rotating and machining of a workpiece. The main function of a lathe is to remove metal from a piece of work to give it the required shape and size. This is accomplished by holding the work securely and rigidly on the machine and then turning it against cutting tool which will remove metal from the work in the form of chips.

3.1 Construction and working of lathe:-

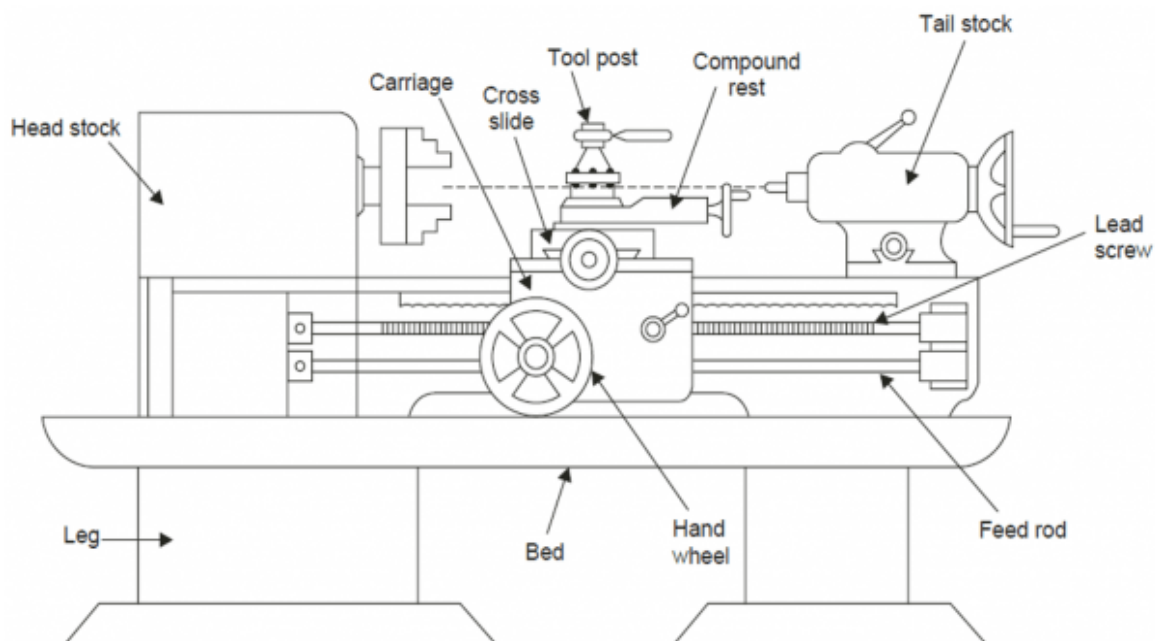

- The lathe is a machine tool which holds the workpiece between two rigid and strong supports called centers or in a chuck or face plate which revolves.
- The cutting tool is rigidly held and supported in a tool post which is fed against the revolving work.
- The normal cutting operations are performed with the cutting tool fed either parallel or at right angles to the axis of the work.
- The cutting tool may also be fed at an angle relative to the axis of work for machining tapers and angles.

The main components of lathe machine are—

1. **Bed**:- The bed is a heavy, rugged casting in which are mounted the working parts of the lathe. It carries the headstock and tail stock for supporting the workpiece and provides a base for the movement of carriage assembly which carries the tool.
2. **Legs**:- The legs carry the entire load of machine and are firmly secured to floor by foundation bolts.
3. **Headstock**:- The headstock is clamped on the left hand side of the bed and it serves as housing for the driving pulleys, back gears, headstock spindle, live centre and the feed reverse gear. The headstock spindle is a hollow cylindrical shaft that provides a drive from the motor to work holding devices.
4. **Tailstock**:- The tailstock is a movable casting located opposite the headstock on the ways of the bed. The tailstock can slide along the bed to accommodate different lengths of workpiece between the centers. A tailstock clamp is provided to lock the tailstock at any desired position. The tailstock spindle has an internal taper to hold the dead centre and the tapered shank tools such as reamers and drills.
5. **Carriage**:- The carriage is located between the headstock and tailstock and serves the purpose of supporting, guiding and feeding the tool against the job during operation. The main parts of carriage are:-
 - **Saddle**:- The saddle is a H-shaped casting mounted on the top of lathe ways. It provides support to cross-slide, compound rest and tool post.
 - **Cross slide**:- The cross slide is mounted on the top of saddle, and it provides a mounted or automatic cross movement for the cutting tool.
 - **Compound rest**:- The compound rest is fitted on the top of cross slide and is used to support the tool post and the cutting tool.
 - **Tool post**:- The tool post is mounted on the compound rest, and it rigidly clamps the cutting tool or tool holder at the proper height relative to the work centre line.
 - **Apron**:- The apron is fastened to the saddle and it houses the gears, clutches and levers required to move the carriage or cross slide. The engagement of split nut lever and the automatic feed lever at the same time is prevented so the carriage along the lathe bed.
6. **Gear box**:- The quick-change gear-box is placed below the headstock and contains a number of different sized gears.

Construction and working of CNC lathe machine:-

CNC stands for Computer Numerical Control. When computers are used to control a Numerical Control (NC) machine tool than the machine is called CNC machine. The cutting operations performed by the CNC is called CNC machining. The Various machining services in which CNC machine is used are known as CNC machining services. In **CNC machine shoo**, programs are designed or prepared first, and then it is fed to the CNC machine. According to the program, the CNC controls the motion and speed of the machine tools.

Main parts of CNC machine:-

1. **Input Devices**:- These are the devices which are used to input the part program in the CNC machine. There are three commonly used input devices and these are punch tape reader, magnetic tape reader and computer via RS-232-C communication.
2. **Machine Control Unit (MCU)**:- It is the heart of the CNC machine. It performs all the controlling action of the CNC machine, the various functions performed by the MCU are
 - It reads the coded instructions fed into it.
 - It decodes the coded instruction.

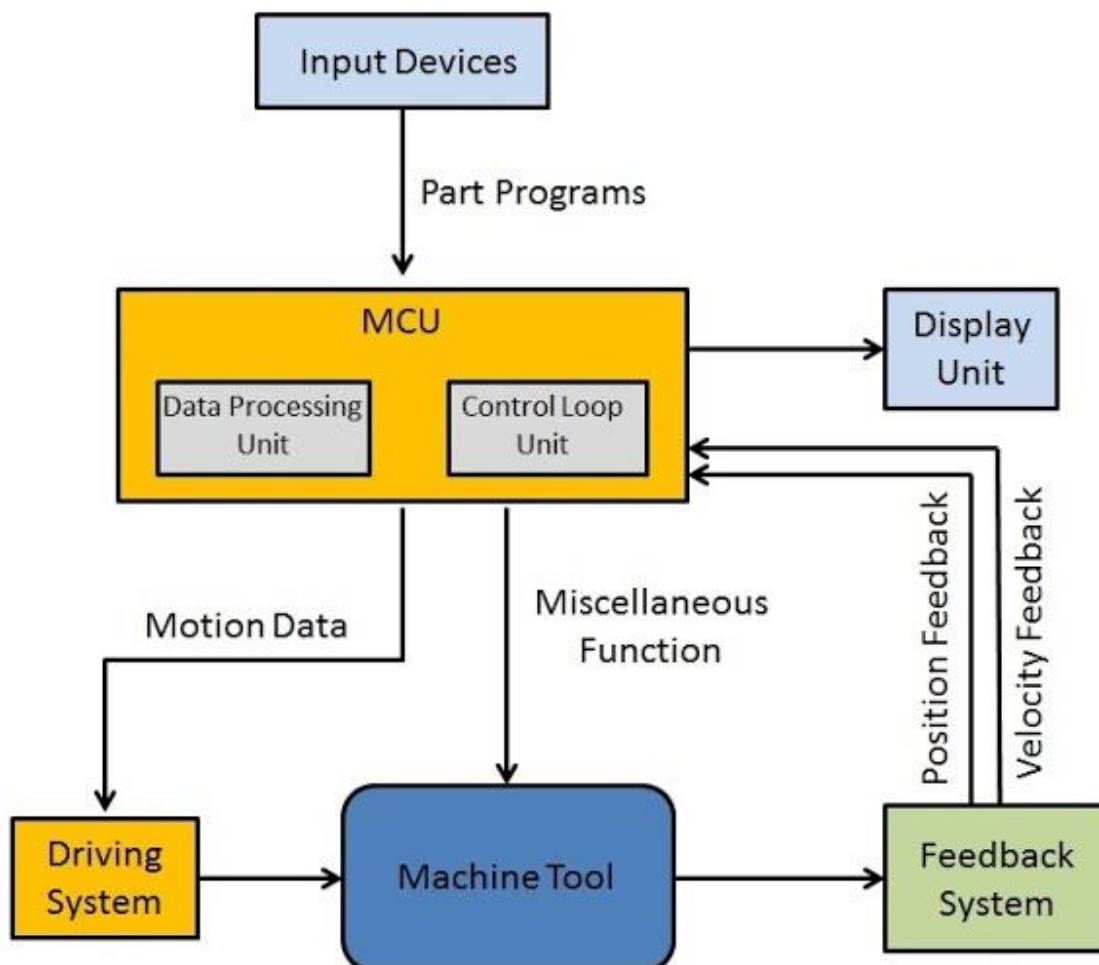

- It implements interpolation (linear, circular and helical) to generate axis motion commands.
- It feeds the axis motion commands to the amplifier circuits for driving the axis mechanisms.
- It receives the feedback signals of position and speed for each drive axis.
- It implements the auxiliary control functions such as coolant or spindle on/off and tool change

3. Machine Tool:- A CNC machine tool always has a slide table and a spindle to control of the position and speed. The machine table is controlled in X and Y axis direction and the spindle is controlled in the Z axis direction.

4. Driving System:- The driving system of a CNC machine consists of amplifier circuits, drive motors and ball lead screw. The MCU feeds the signals (i.e. of position and speed) of each axis to the amplifier circuits. The control signals are then augmented (increased) to actuate the drive motors. And the actuated drive motors rotate the ball lead screw to position the machine table.

5. Feedback System:- This system consists of transducers that act as sensors. It is also called a measuring system. It contains position and speed transducers that continuously monitor the position and speed of the cutting tool located at any instant. The MCU receives the signals from these transducers and it uses the difference between the reference signals and feedback signals to generate the control signals for correcting the position and speed errors.

6. Display Unit:- A monitor is used to display the programs, commands and other useful data of CNC machine.

Operation carried out in a lathe:-

Various operations in a lathe machine are –

1. Turning:-

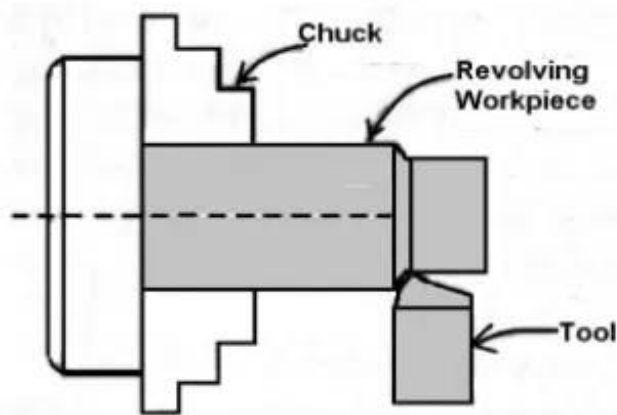

Turning Operation

- It is the most common type of operation in all lathe machine operations. Turning is the operation of removing the excess material from the workpiece to produce a cylindrical surface to the desired length.
- The job held between the centre or a chuck and rotating at a required speed. The tool moves in a longitudinal direction to give the feed towards the headstock with proper depth of cut . The surface finish is very good.

There are different types of turning operations-

Straight Turning:-

The workpiece is held on the chuck and it is made to rotate about the axis, and the tool is fed parallel to the lathe axis. The straight turning produces a cylindrical surface by removing excess metal from the workpiece.

Rough Turning:-

It is the process of removal of excess material from the workpiece in minimum time by applying high rate feed and heavy depth of cut. in rough turning the average depth of cut 2mm to 4mm can be given and feed is from 0.3 to 1.5mm per revolution of the work.

Finish turning:-

It is the operation of machining a workpiece to the required dimension with in the tolerance specified. In finish turning depth of cut and feed may be the order of 0.5-1mm and from 0.1-0.3 mm per revolution of the workpiece respectively.

2. Thread cutting:-

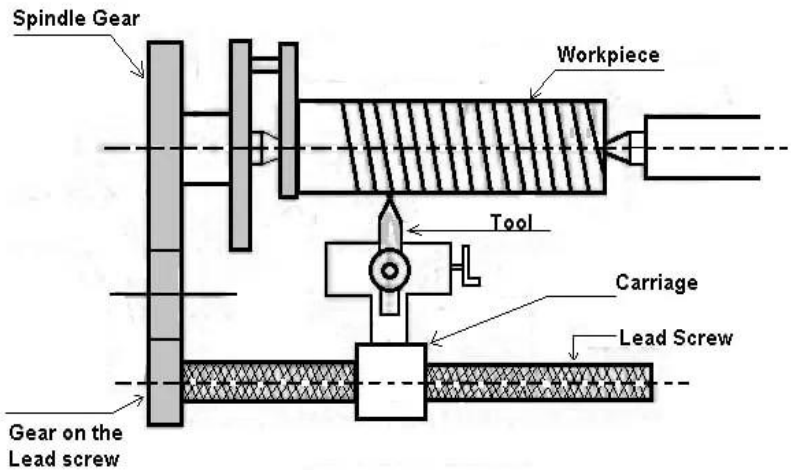

Thread Cutting

- When the threads or helical grooves are formed on the out surface of the workpiece is called external thread cutting. When the threads or helical grooves are formed on the inner surface of the workpiece is called internal thread cutting.
- The workpiece is rotating between the two centres i.e., live centre and dead centre of the lathe.
- Here the tool is moved longitudinally to obtain the required type of the thread. When the tool is moved from right to the left we get the left-hand thread. Similarly, when the tool is moved from left to the right we get the right-hand thread.

- Here the motion of the carriage is provided by the lead screw. A pair of change gears drives the lead screw and by rotating the handle the depth of cut can be controlled.

3. Taper turning:-

- A "taper" is the uniform increase or decrease in the diameter of the workpiece and measured along with its length.
- Taper turning means to produce a conical shape by a gradual reduction in diameter from a cylindrical workpiece.
- The amount of taper in the workpiece is usually specified on the basis of the difference in diameter of the taper to its length.

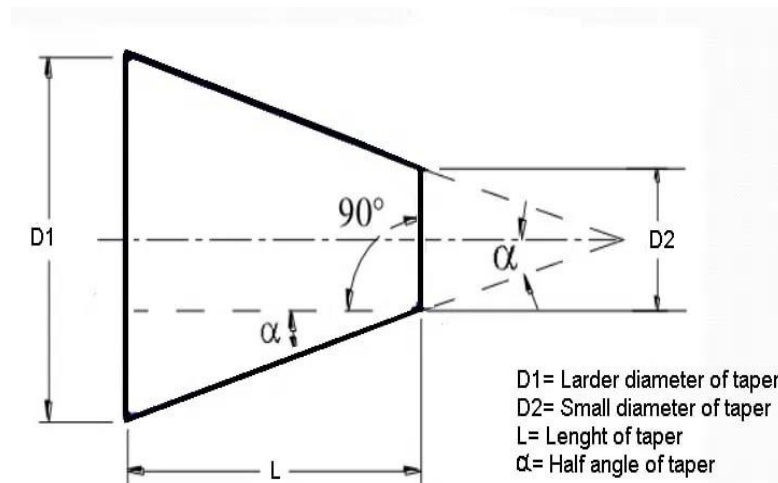

- For preparing a taper turning, if the angle α the angle of taper, then the formula for taper angle is

$$\tan \alpha = \frac{D-d}{2l}$$

$$\text{Or, } \alpha = \tan^{-1} \frac{D-d}{2l}$$

4. Facing:-

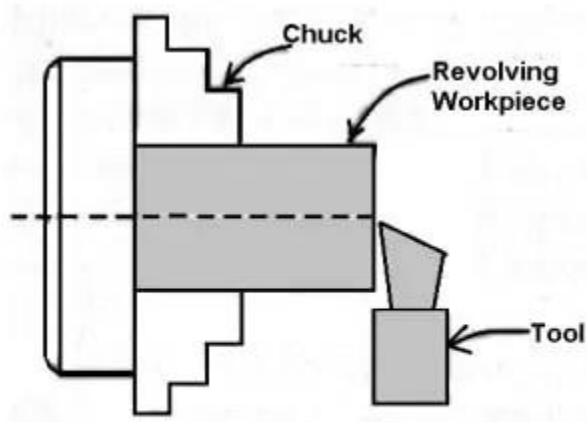

Facing Operation

It is an operation of reducing the length of the workpiece by feeding the perpendicular to the lathe axis. This operation of reducing a flat surface on the end of the workpiece. For this operation, regular turning tool or facing tool may use. The cutting edge of the tool should set to the same height as the centre of the workpiece.

5. Parting off:-

Parting-off is the operation of cutting a workpiece after it has been machined to the desired size and shape. The process involves rotating the workpiece on a Chuck and feeding by a narrow parting-off tool perpendicular to the lathe axis by rotating the crossslide screw by hand. The parting tool is first fed through a certain depth it is then withdrawn , and two or more cuts are made at the two sides of the central groove.

6. Knurling:-

It is an operation of obtaining a diamond shape on the workpiece for the gripping

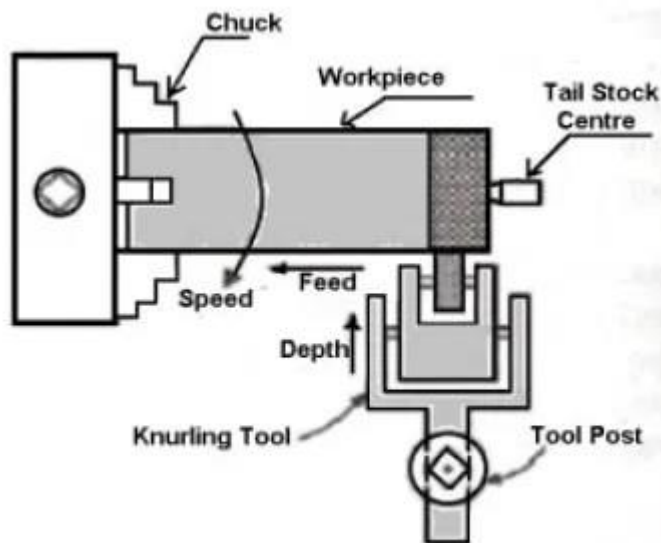

Knurling

purpose. This is done to provide a better gripping surface when operated by hands. It is done using a knurling tool. The tool consists of a set of hardened steel roller, and it is held rigidly on the tool post.

Knurling is done at the lowest speed available on a lathe. It is done on the handles and also in case of gauges. The feed varies from 1 to 2 mm per revolution. Two or three cuts may be necessary to give the full impression.

7. Drilling:-

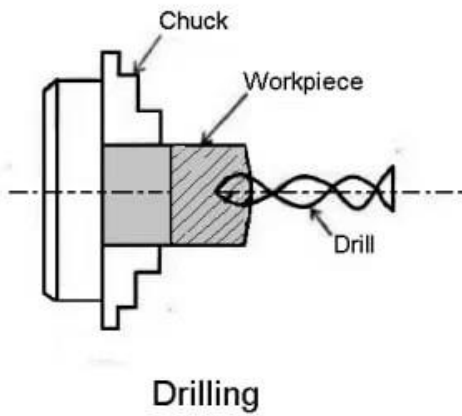

Drilling is the operation of producing a cylindrical hole in a workpiece. It is done by a rotating tool, the rotating side of the cutter, known as a drilling drill. In this operation, The workpiece is revolving in a chuck or a faceplate and the drill is held in the tailstock drill holder or drill chuck.

8. Reaming:-

Reaming is the operation of finishing and sizing a hole which has been already drilled

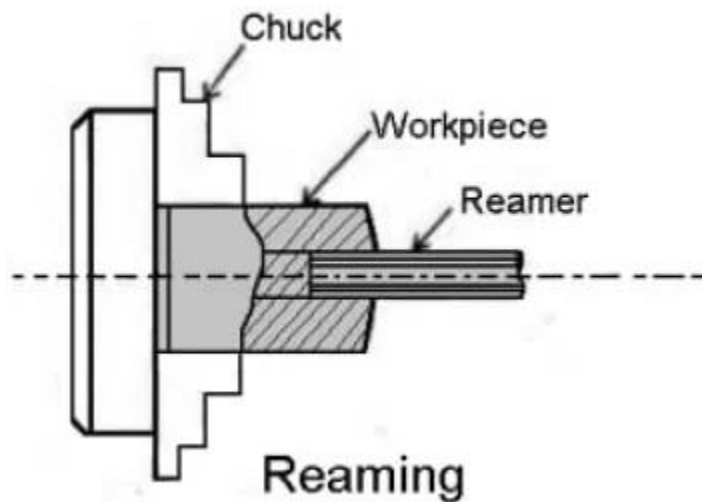

or bored. The tool is used is called the reamer, which has multi-plate cutting edges.

9. Boring:-

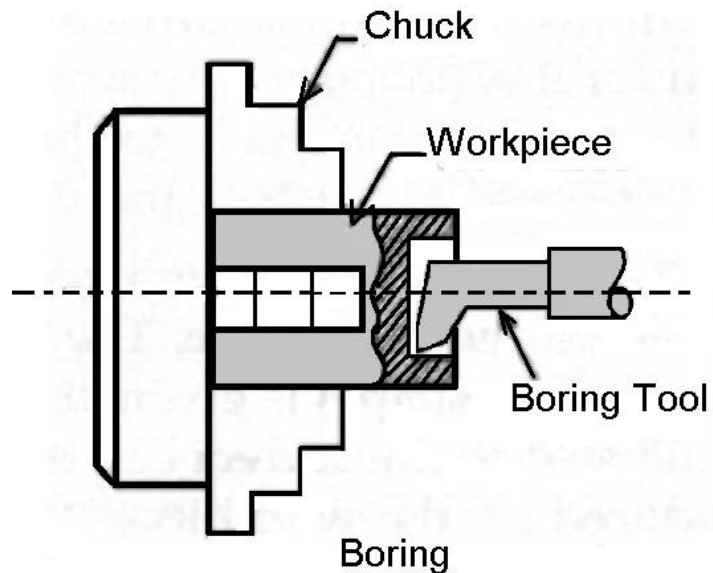

Boring is the operation of enlarging the hole which is already drilled, punched or forged. It cannot produce a hole. Boring is similar to the external turning operation and can be performed in a lathe. In this operation, the workpiece is revolved in a chuck or a faceplate and the tools which are fitted to the tool post is fed into the work.

10. Tapping:-

Tapping is the operation of cutting internal threads of small diameter using a

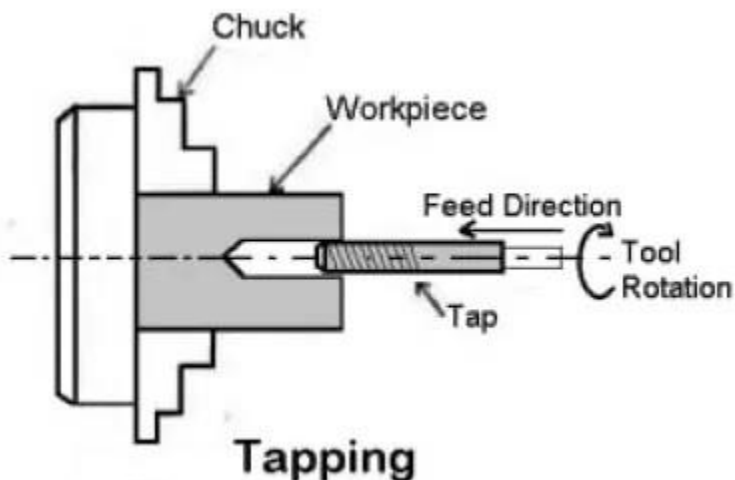

multi-point cutting tool called the tap. In a lathe, the work is mounted on a chuck or on a faceplate and revolved at a very slow speed. A tap of the required size held on a special fixture is mounted on the tailstock spindle.

Safety measures during machining:-

1. Reduce Workplace Stress:-

Workplace stress can include long work hours, heavy workloads, conflict with coworkers, and/or improper or dangerous working conditions. These types of issues can lead to distraction or rushing. If you are experiencing any of these issues, it is best to talk to your manager.

2. Use Tools and Machines Properly :-

Improper use of tools and machines can mean a number of different things including: using the wrong tool for a task, not knowing how to properly use a machine, or using heavy machinery and tools without the proper training. Before you use any type of machine or tool at work, make sure that you have received the proper procedure and safety trainings. If you don't know how to use something or are not comfortable, don't use it .

3. Use Mechanical Aids When Possible:-

The number one cause of workplace injury is overexertion. Injuries to the back, neck, limbs, or spine can be serious. The use of mechanical aids, including forklifts, handcarts, or lift tables, when lifting, pulling, or carrying can reduce these injuries.

4. Wear Protective Equipment:-

Personal protective equipment or PPE is vital to staying safe at work. Gloves, hard hats, goggles, ear protection, and body protection can prevent serious injury in most environments. Necessary PPE varies from job to job but should protect from physical, electrical, heat, chemicals, biohazards, and air borne material hazards.

5. Stay Sober:-

Alcohol and drugs account for over 3% of all workplace injuries and fatalities. These substances can reduce the ability to exercise the proper judgement, decrease concentration, and reduce motor skills.

6. Follow Correct Procedures, Don't Take Shortcuts:-

Shortcuts might seem like a good idea in order to save time, but not following the proper procedures increases the likelihood that you will do something incorrectly. Performing a task incorrectly can lead to injuries immediately or in the future and can cost your company time and money.

7. Be Alert and Awake:-

Being properly rested reduces the likelihood of accidents, improves concentration, and fine motor skills. Being exhausted on the job causes sloppiness which can injury both you and your coworkers.

7. Take Regular Breaks:-

Taking breaks helps to keep you alert and focused. Long periods of time without proper breaks increase the chance of accidents and decreases alertness and concentration. It can also reduce productivity. If you are not receiving regular breaks, talk to your manager.

3.2 Difference between capstan lathe and engine lathe:-

- The headstock of a capstan lathe is similar to that of an engine lathe in construction but possess wide range of speeds, and is of heavier in construction.
- For similar sizes of lathe, an engine lathe will require 3 h.p to drive it's spindle and other parts , a capstan lathe will demand 15 h.p for high rate of production.
- For a capstan lathe, the four way tool post which holds four tools and each tool may be brought into operation in a regular order. Where as in the case of an engine lathe the tool post holds only one tool and for different operations the tool must be changed and will require too much setting of time in respective works.
- In a capstan lathe , the tailstock is replaced by a turret. This is a six sided block each side of which may carry one or more tools. Thus , in place of tailstock in a engine lathe which can accommodate only one tool.
- In a capstan lathe, two or more tools may be mounted on the same face of the turret, this features reduces total operational time. In a engine lathe , this type of arrangement is quite uncommon.
- The labour cost required to operate a capstan lathe is less that required in a engine lathe.
- Capstan lathe is not usually fitted with leadscrews for cutting threads similar to an engine lathe. The threads are usually cut by die heads and taps in a capstan lathe.
- In capstan lathe, turret movement can be controlled automatically, but in engine lathe tool movement can control manually.
- Capstan lathe is suitable for mass production while engine lathe is not suitable for that.

Major components of capstan lathe:-

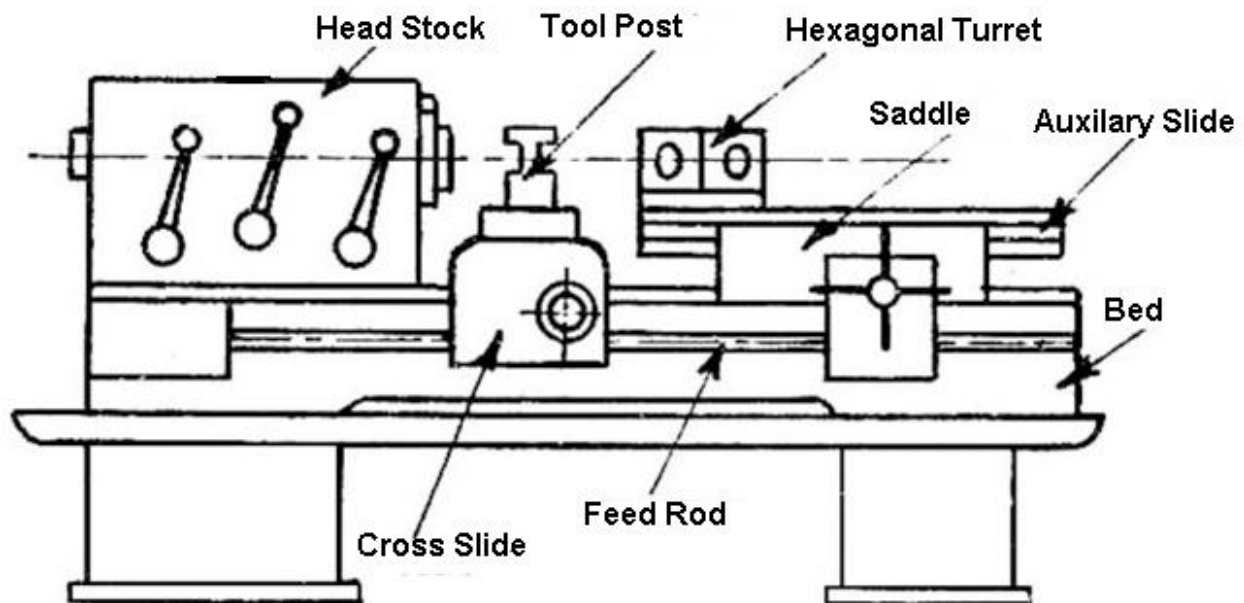

CAPSTAN LATHE MACHINE

The major components of a capstan lathe are—

1. Bed:-

The bed is a long box-like casting with accurate guideways on which carriage and turret saddle are mounted. The bed is designed to ensure strength, rigidity, and permanency of alignment under heavy-duty services. Carriage is mounted over the bed and travels longitudinally.

2. Headstock is a large casting located at the left-hand end of the machine. The headstock of a capstan and turret lathe may be of following types:-

(A) Step Cone Pulley Driven Headstock –

This is the simplest type of the headstock and is fitted with small capstan lathes where the lathe is engaged in machining small and almost constant diameter of workpieces. Only three

or four steps of the pulley can cater to the needs of the machine. The machine requires special counter shaft unlike that of an engine lathe, where starting, stopping, and reversing of the machine spindle can be affected by simply presenting a foot pedal.

(B) Electric Motor Driven Headstock :-

In this type of headstock the spindle of the machine and the armature shaft of the motor are the same. Any speed variation and reversal is affected by simply controlling the motor. Three or four speeds are available and the machine is suitable for a smaller diameter of workpieces rotated at high speed.

(C) All Geared Headstock :-

On the larger lathes, the headstock is geared and different mechanisms are employed for speed changing by actuating levers. The speed changing may be affected without stopping the machine.

3. Turret Saddle:-

This saddle replaces the tailstock of a center lathe. It is mounted directly on the lathe bed on the same side as a tailstock in the center lathe. It can be of two types one is that which travels longitudinally along with the tool when it is fed into the job and the turret head carrying the tool is mounted directly on it. In the other type, it is provided with a slide that moves in the guideways made in it. In this type the turret head is mounted on the slide. As the overhang of the slide is kept limited, the saddle can be moved along the bed and secured at the desired position. During the operation it remains stationary and the tools are fed longitudinally by moving the slide. The former type of saddle is provided on the saddle type turret lathes and the latter type on the ram type turret lathes or capstan lathes.

4. Cross Slide and Saddle:-

In small capstan lathes, hand-operated cross slide and saddle are used which are clamped on the lathe bed at the required position.

5. Multiple tool holders:-

Tool holders to multiply the available tools on turning centers with Y axis. The enhancement of available cutting tools allows the production of more complex and a

more comprehensive range of work pieces on a turning center without changing the machine set up.

It is generally used for-

- Reduced setup and production time.
- Multiplication of Productivity.
- Reduced labour cost.

Difference between capstan lathe and turret lathe:-

<u>Capstan lathe</u>	<u>Turret lathe</u>
It is a lightweight machine.	It is a heavyweight machine.
In capstan lathe, the turret tool head is mounted over the ram and that is mounted over the saddle.	In turret lathe, the turret tool head is mounted over the saddle like a single unit
For providing feed to the tool, ram is moved.	For providing feed to the tool, the saddle is moved.
Because of no saddle displacement, Movement of turret tool head over the longitudinal direction of bed is small along with the ram.	Turret tool head moves along with the saddle over the entire bed in the longitudinal direction.
Used for shorter workpiece because of limited ram movement.	Used for longer workpiece because of saddle movement along the bed.
Its working operations are fast because of lighter in constructions.	Its working operations are slower because of heavier in constructions.
Heavy cuts on the workpiece cannot be given because of non-rigid construction.	Heavy cuts on the workpiece can be given because of the rigid construction of the machine.
For indexing turret tool head, the hand wheel of	For indexing turret tool head, the turret is rotated manually

the ram is reversed and turret tool index automatically.	after releasing the clamping lever.
In capstan lathe, Collet is used to grip the Job.	In turret lathe, power Jaw chuck is used to grip the Job.
These are usually horizontal lathes.	Turret lathes are available in horizontal and vertical lathes.
Used for machining workpiece up to 60 mm diameter.	Used for machining workpiece up to 120 mm diameter.

3.3 Major components of turret lathe:-

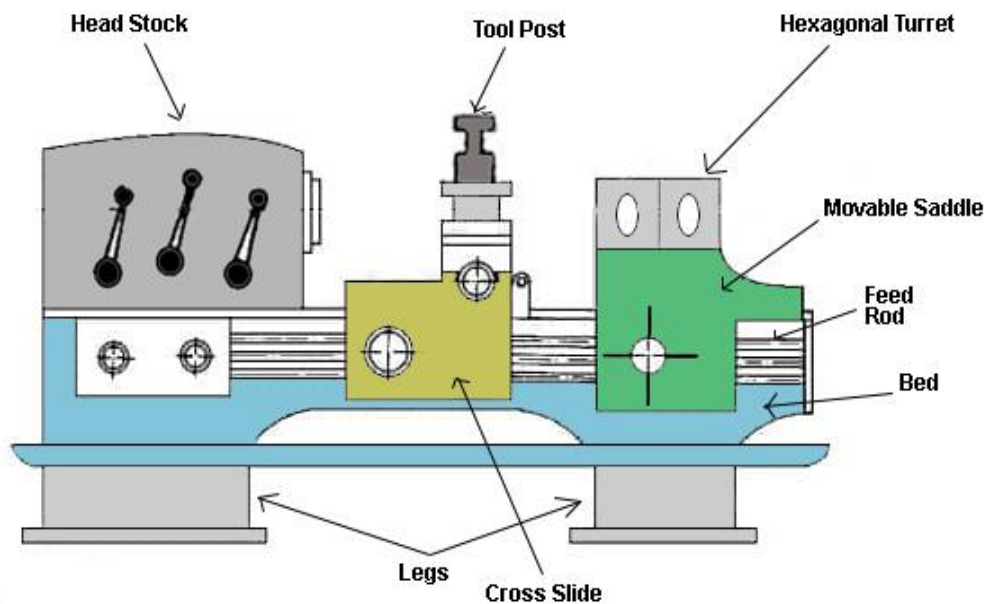

TURRET LATHE

1. Bed:-

Bed is present over two legs. This bed is made up of cast iron as it has to withstand a lot of load and it must be shock absorbing. This bed is made through casting.

2. **Head Stock:-**

All the gearing mechanism or driving mechanism of this lathe machine is present inside the headstock. It has gears, pulleys, or motor is present based on the driving mechanism used in the lathe.

3. **Chuck:-**

Chuck is used to hold and rotate the workpiece. The chuck is bolted to the spindle and rotates when the spindle rotates.

This chuck can be of two types 3 jaw chuck or 4 jaw chuck. 3 jaw chuck is also known as universal chuck.

3 jaw chuck is used to hold cylindrical jobs and 4 jaw chuck can be used to hold square, hexagonal and irregular shaped jobs.

4. **Driving Clutch:-**

It is used to engage and disengage the connection between the gears and the spindle. At starting the gears and spindle are disengaged but when motion is needed, the gears and the spindle can be engaged using driving clutch.

5. **Guideways:-**

Guideways are the predefined slotted path over which the carriage and saddle moves.

6. **Feed Rod:-**

Feed Rod provides precise longitudinal movement to the carriage. The carriage move over the feed rod and the guideways. It is named as feed rod because it provides movement to the carriage.

7. **Saddle:-**

Saddle can move left and right over the guide ways. There are two saddles present in this turret lathe. One saddle is to carry the tool post and another saddle is to carry the hexagonal turret.

8. **Cross Slide:-**

Cross Slide can move across the bed perpendicular to the direction of the movement of saddle. This cross slide is present between the tool post and saddle in the turret lathe.

9. **Tool Post:-**

The tool post is used to hold the tool in the turret lathe machine. It is particularly used to hold single point cutting tool. This tool post can move horizontally in the left or

right directions. It can also move across the bed using the cross-slide. It can be moved using hand wheel or can be moved automatically.

10. Hexagonal Turret:-

A hexagonal turret is used to hold different tools for different operations of the workpiece. It is called a hexagonal turret because 6 tools can be held simultaneously in it. It is directly mounted on the saddle in this lathe. This hexagonal turret is also present in the capstan lathe but a ram is present between the saddle and the hexagonal turret.

Unlike the simple lathe machine, this turret lathe does not have **tailstock**.

3.4 Layout for preparation of a hexagonal bolt and bush:-

For preparing a hexagonal bolt the setting and machining operations are performed in the following order:

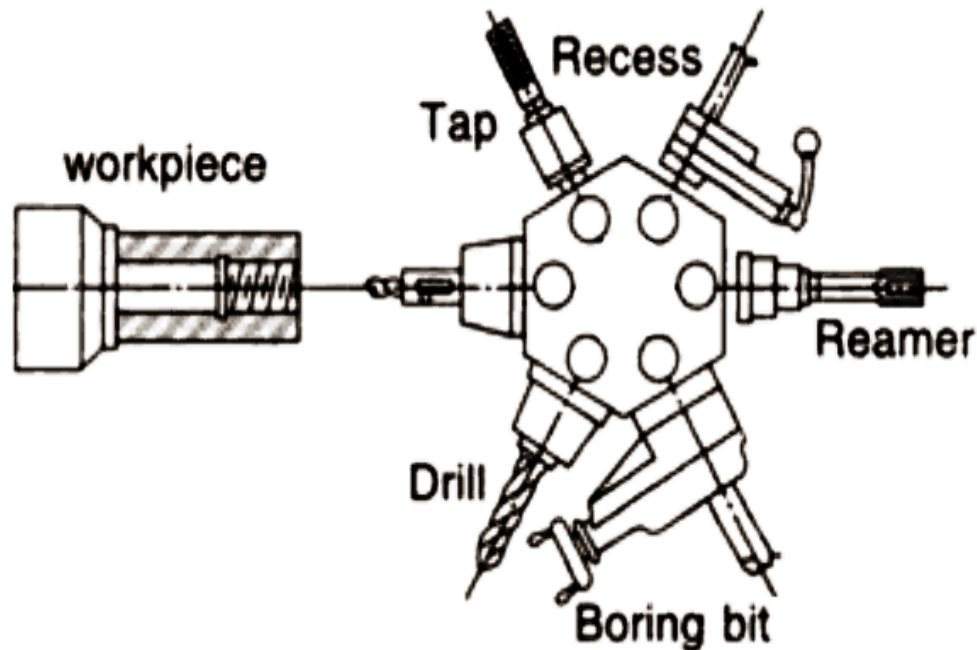

1. Setting of the bar stops:-

The bar is set at a distance of 70mm from the collet face by using a slip gauge. An extra length of 10 mm than the bolt length is allowed, 4mm for parting off tool may penetrate deep into the work without any interference.

2. Setting of the roller steady box turning tool:-

The roller steady box turning tool is set on the next turret face for turning a diameter of 16 mm. The stop for turning the tool is set 20mm from the collet face by a slip gauge. The rollers are set slightly behind the cutting edges approximately 1.5 mm.

3. Setting of bar ending tool:-

The bar ending tool is set on the next turret face and is brought into operation after turning the bar. The stop is adjusted in the position by using a slip gauge.

4. Setting of self opening die head:-

The self opening die head is mounted on the next face of the turret and the dies are fitted into it to cut a thread of 16 mm diameter. The stop is adjusted in a position keeping in view the pulling out length of the die head for self releasing.

5. Setting of chamfering tool:-

The chamfering tool is mounted on the four station turret on the cross slide and the extreme longitudinal position of the saddle is adjusted by a stop. The cross feed movement of the cross slide is adjusted by a stop.

6. Setting of parting off tool:-

The parting off tool is set on the rear tool post on the cross slide and the longitudinal position of tool is adjusted by the stop set at a distance of 6mm from the turret face.

POSSIBLE QUESTIONS

SHORT QUESTION

1. Define lathe.

Ans:- Lathe is a machine tool on which rotating and machining of a workpiece. The main function of a lathe is to remove metal from a piece of work to give it the required shape and size. This is accomplished by holding the work securely and rigidly on the machine and then turning it against cutting tool which will form the work in the form of chips.

2. Write the parts of a lathe.

Ans :- 1.leg

2 .bed

3. Carriage

4. Lead screw

5. Head stock

6. Tailstock

3. Write the operations in lathe.

Ans:- turning, facing, threading, chamfering, knurling, taper turning, etc.

LONG QUESTION

1. Explain with neat sketch the working of lathe.
2. Write the difference between capstan lathe and engine lathe.
3. Explain with neat sketch the working of capstan lathe.
4. Explain the operations of lathe with neat sketch.
5. Draw the layout for preparing of a hexagonal bolt.

CHAPTER-04

SHAPER

Introduction:-

The **Shaper Machine** is a reciprocating type of machine tool basically used to produce Horizontal, Vertical or Inclined flat surfaces by means of straight-line reciprocating single-point cutting tools similar to those which is used in lathe operation.

4.1 Application of shaper machine:-

- To generate straight and flat surfaces.
- Smooth rough surfaces.
- Make internal splines.
- Make gear teeth.
- To make dovetail slides.
- Make key ways in gears.
- Machining of die, punches, straight and curved slots.

4.2 Construction and working of shaper machine:-

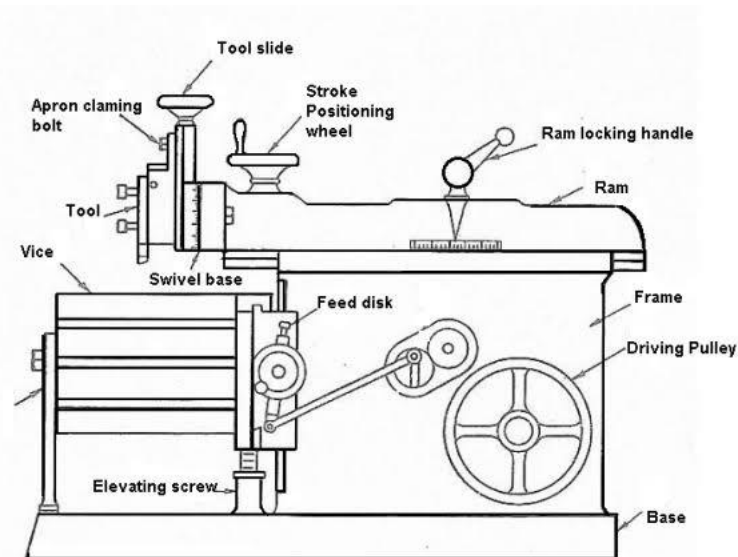

- A shaper machine holds the Single point cutting tool in ram and workpiece is fixed over the table.

- The ram holding the tool reciprocates over the workpiece and metal is cut during the forward stroke called a cutting stroke and
- No metal is cut during its return stroke is called an Idle stroke.
- The feed is given at the end of the cutting stroke.
- Generally, the cutting stroke is carried out at slow speed and the idle stroke is carried at high speed with the help of quick return mechanism.

The major components of shaper machine are—

1. Base:-

The Base is designed to take the entire load of the machine tool and it is bolted to the floor of the shop. This is made of grey cast iron to resist vibration and to take the compressive load.

2. Column:-

The column is a Box like casting made up of cast iron and mounted on a base. It is provided with accurately machined guideways on the top on which the ram reciprocates. The guideways are also provided on the front vertical face for the movement of cross rail. The column encloses the ram driving mechanism.

3. Cross rail:-

- The cross rail is mounted on the ground vertical guideways of the column.
- It consists of two parallel guideways on its top perpendicular to the ram axis is called as a saddle to move the table in crosswise direction by means of a feed screw.
- The table can be raised or lowered to accommodate different sizes of the job by rotating elevating screw which causes the cross rail to slide up and down on the vertical face of the column.

4. Saddle:-

- It is mounted on the cross rail to hold the table firmly on its top.
- The crosswise movement of the saddle causes the table to move crosswise direction by rotating the cross feed screw.

4. Table:-

- It is mounted on the **saddle**.

- It can be moved crosswise by rotating the cross feed rod and vertically by rotating the elevating screw.
- The table is a box-like casting with accurately machined top and side surfaces. These surfaces having t-slots for clamping the work.
- In Universal shaper, the table may be swiveled on a horizontal axis and its upper part may be tilted up or down.
- In heavy Shaper, the front face of the table is supported by adjustable table support to give more rigidity.

5. Ram:-

- It is a reciprocating member of the shaper which holds the tool and reciprocates on the guideways on the top of the column by means of quick return motion mechanism.
- It houses the screwed shaft for altering the position of the RAM with respect to the work. The RAM is in semi-cylindrical form and heavily ribbed inside to make it more rigid.

(4.4) 6. Tool Head:-

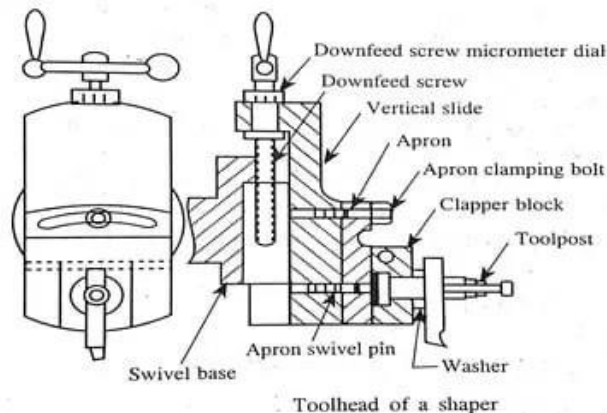

- The tool head holds the cutting tool firmly and provides both vertical and angular movement to the tool with the help of a down feed screw handle.
- The head allows the tool to have an automatic relief during the return stroke.
- The vertical slide of a tool head consists of a swivel base which is graduated in degrees. So, the vertical slide can set at any angle with the work surface.
- The amount of feed or depth of cut may be adjusted by a micrometer dial on top of the down feed screw.

A tool head again consists of:

- Apron
- Clapper box and clapper block
- **Apron** consisting of clapper box and tool post is clamped on the vertical slide by the screw.
- The **apron** Can be swiveled upon the apron swivel pin towards left or right.
- The **clapper box** houses the **clapper block** by means of a hinge pin.
- The **tool post** is mounted on the **clapper block**.
- During forwarding cutting stroke the clapper block keeps the rigid support to the tool by fitting securely into clapper box and while returning stroke the tools slide over the work by lifting, the block out of clapper boxes.

4.3 Automatic table feed mechanism:-

- The automatic feed mechanism of the table is very simple. This is done by rotating a ratchet wheel, mounted at the crossfeed screw.
- This enables a corresponding equal rotation of the cross feed screw after each stroke.
- It consists of a slotted disc, which carries a T-slot, as shown in the figure. In this slot is fitted an adjustable pin and to this is attached a connecting rod.
- The other end of the connecting rod is attached to the lower end of the rocker arm of the pawl mechanism.

- The rocker arm swings about the screw C, and at its upper end carries a spring-loaded pawl, as

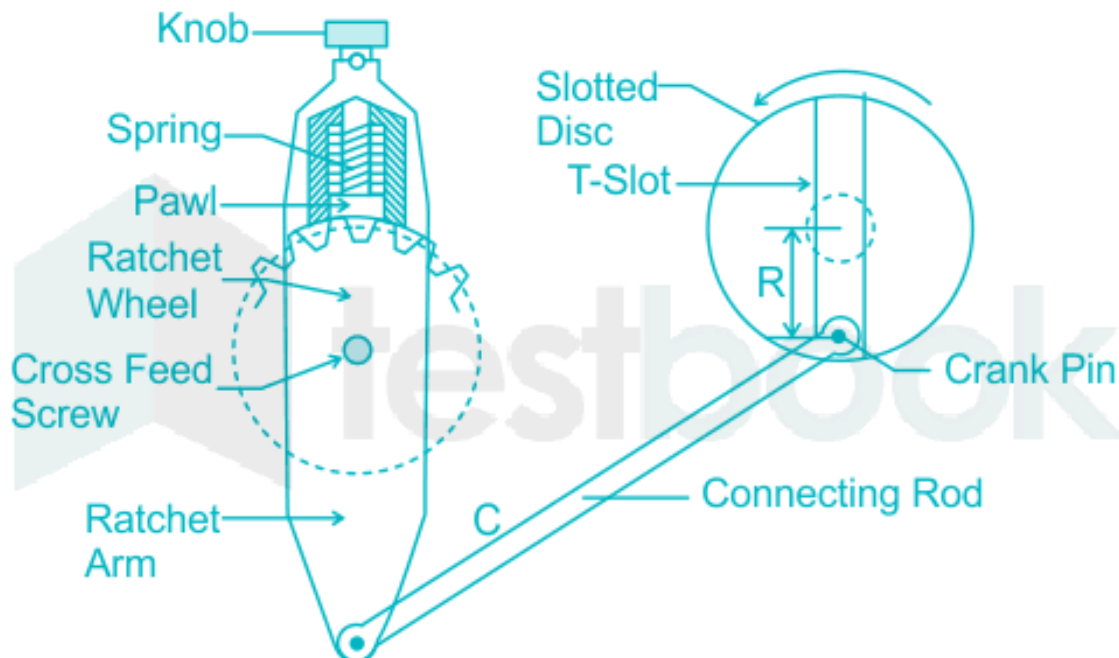

shown Note, that the lower end of the pawl is bevelled on one side.

- This arrangement helps the power feed to operate in either direction, but the same should be set to operate during the return stroke only.
- If otherwise, the mechanism will be subjected to severe stress. In some latest types of shapers, can driven feed mechanisms are provided which are more efficient and provide a wider range of feed.
- Variation in the feed can be provided by varying the distance R between the disc centre and the Centre of the adjustable pin.
- Larger the said distance greater will be the feed and vice versa. The amount of feed to be given depends upon the type of finish required on the job.
- For rough machining, heavier cuts are employed, and thus, a coarse feed is needed. Against this, a finer feed is employed in finishing operations.
- The slotted disc at its back carries a spur gear which is driven by the bull gear. As the disc rotates through this gear the adjustable pin, being eccentric with the disc centre.
- This causes the connecting rod to reciprocate. This, in turn, makes the rocker arm to swing about the screw C to move the pawl over one or more teeth.
- Thus transmit an intermittent motion to the crossfeed screw which moves the table.

4.5 Quick return mechanism:-

- A quick return mechanism is a system to produce a reciprocating effect such that time taken by system in return stroke is less time taken by it in the forward stroke.
- In quick return mechanism, a circular motion is converted into reciprocating motion just like crank and lever mechanism but it has return stroke time is different from forward stroke time.

- This mechanism is used in many machines. Some of them are shaper machines, slotter machines, screw press, mechanical actuator etc. With the help of quick return mechanism, the time needed to cutting is minimized.

Types of Quick Return Mechanism:-

1. Hydraulic shaper mechanism
2. Whitworth quick return mechanism
3. Crank and slotted link mechanism

Hydraulic shaper mechanism:-

Hydraulic drive mechanism is one of the mechanism used in shaper machine. In this mechanism, the ram is moved forward and backward by a piston moving in a cylinder placed under the ram. This machine consists of a constant discharge oil pump, a cylinder, a valve chamber and a piston. The piston rod is bolted to the ram body. Hydraulic fluid is used in hydraulic quick return mechanism for the movement of ram.

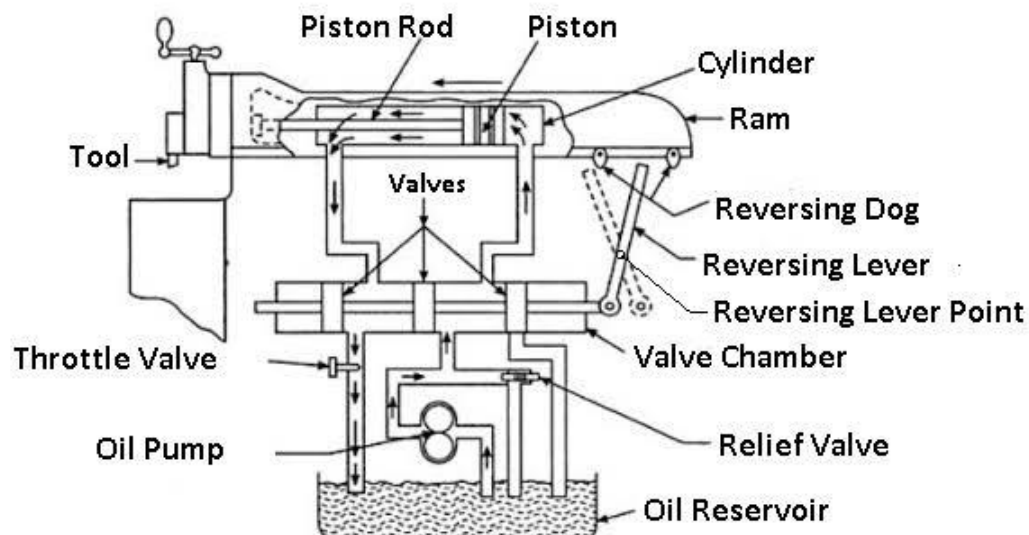

In hydraulic drive, there is a tank at the bottom which contains the hydraulic fluid. This tank is also known as oil reservoir. At first the oil from the reservoir. This oil is passed through the valve chamber present in the right of the oil cylinder exerting pressure on the piston. Any oil present in the left side of the piston is discharged to the reservoir through the throttle valve.

At first the fluid in the tank is pumped out and this fluid passes through the passage present in the right side of the cylinder. This fluid exerts pressure on the piston and the ram of the machine performs forward stroke. When the ram moves forward, the lever changes its position and hits the reversing dog. As the lever changes its position, the three valves connected to the lever also change their position and now the oil can pass through the passage present in the left side of the cylinder. After the forward stroke is completed, the valves changes its position and now the pumped fluid from the reservoir moves

from the passage present in the left side of the piston. Also, the passage through which the oil return to the reservoir opens and get connected to the right passage and the fluid present on the right side of the piston is discharge to the reservoir.

As the fluid moves towards the left side of the piston, the piston which is attached to the ram moves towards right and return stroke is performed by the ram. At the end of the return stroke, another dog hit against the lever and the direction of the lever as well as the stroke changes.

In this way, the forward and the return stroke of the ram is repeated. The quick return takes place due to difference in the stroke volume of cylinder at both ends. The volume of passage at the left side is less than the volume of the passage on the right side.

As the pump is constant discharge pump, same amount of oil will be passed on the both passage. So the pressure in the passage with less volume will be more and the return stroke will be faster than the forward stroke. The cutting speed can be controlled by controlling the flow of oil which can be controlled by using the throttle valve.

Whitworth quick return mechanism:-

This mechanism changes the rotary motion to oscillatory motion like the crank and lever mechanism. The difference between the crank and lever mechanism and Whitworth mechanism is that in whitworth mechanism the return stroke is faster than the forward stroke while in the crank and lever mechanism the forward stroke is of same speed as that of return stroke.

Parts used in Whitworth mechanism:-

- 1) Slotted Bar.
- 2) Slider
- 3) crank

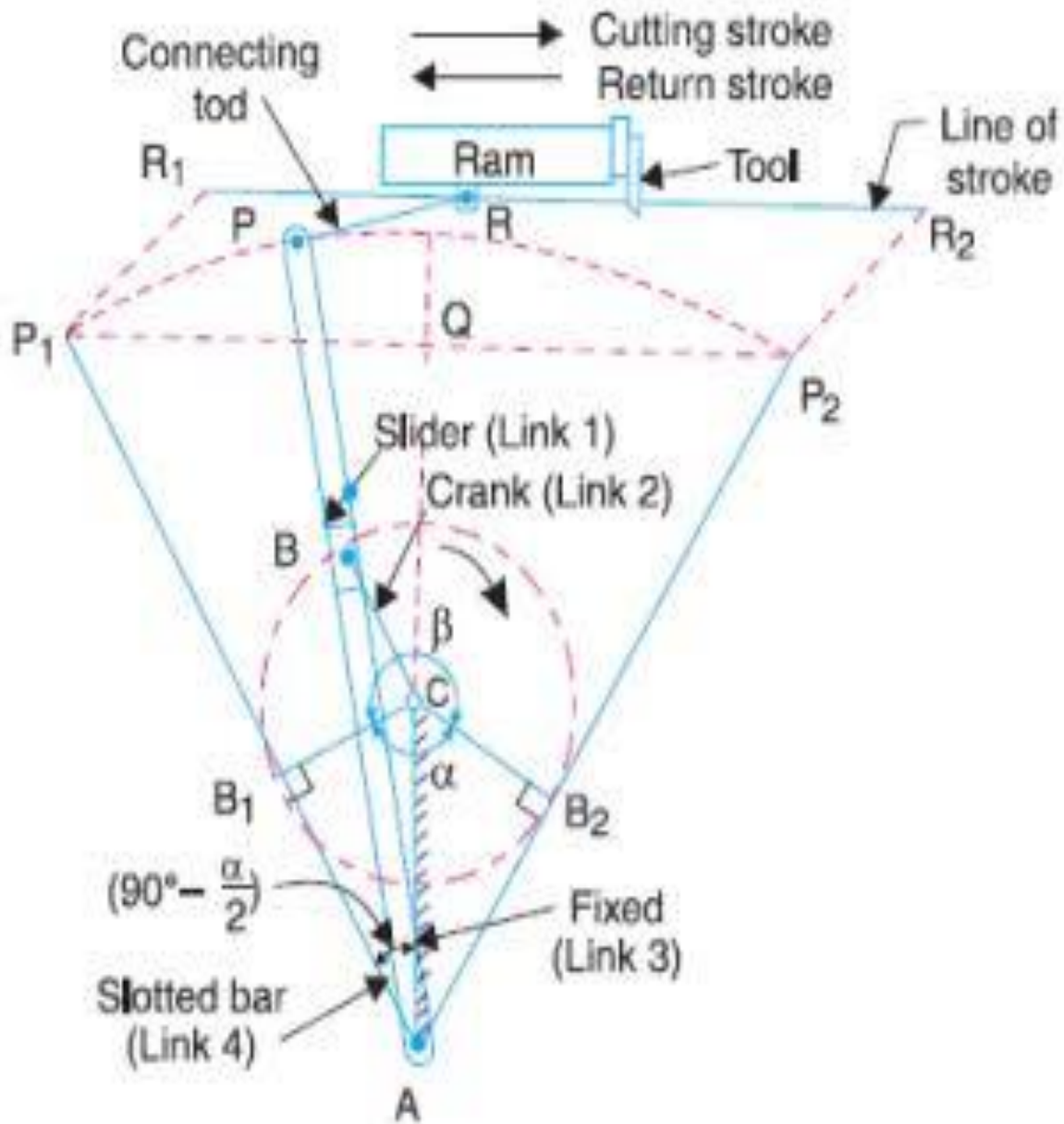

Whitworth quick return mechanism is the second inversion of slider crank mechanism in which the crank is fixed. In this mechanism, the Slider in slotted bar is connected to the crank. When the crank rotates, the slider will slide inside the slotter bar and the slotted bar will oscillate. As the slotted bar oscillate, the ram will move in forward and backward direction.

The return stroke or ideal is faster than the forward stroke in this mechanism. In the above figure AP is the slotted bar and link 1, CD is link 2, AC which is crank is link 3 and link 4 is the slider.

In this mechanism the link CD i.e. link 2 forming the turning pair is fixed as shown in the figure above. The crank AC revolves with uniform velocity with its centre at A. A sliding block attached to the crank pin at B slides along the slotted bar AP and thus causes AP to oscillate about the pivoted pint A. A short link PR transmits the motion from AP to the ram which carries the tool and thus forward stroke and backward stroke is obtained.

The crank needs to rotate through an angle of (β) for the forward stroke and it needs to rotate through an angle of (α) for forward stroke. As crank moves with uniform angular velocity, time taken to cover angle α will be less than the time taken to cover angle β . Hence time taken in return stroke will be less than time taken in forward stroke. In this way, the quick return mechanism works.

Crank and slotted link mechanism:-

In crank and slotted link mechanism. The power is transmitted to the bull gear by a pinion which receives its power from an individual motor. In a two gear system, the smaller gear is called pinion and the larger gear is called bull gear.

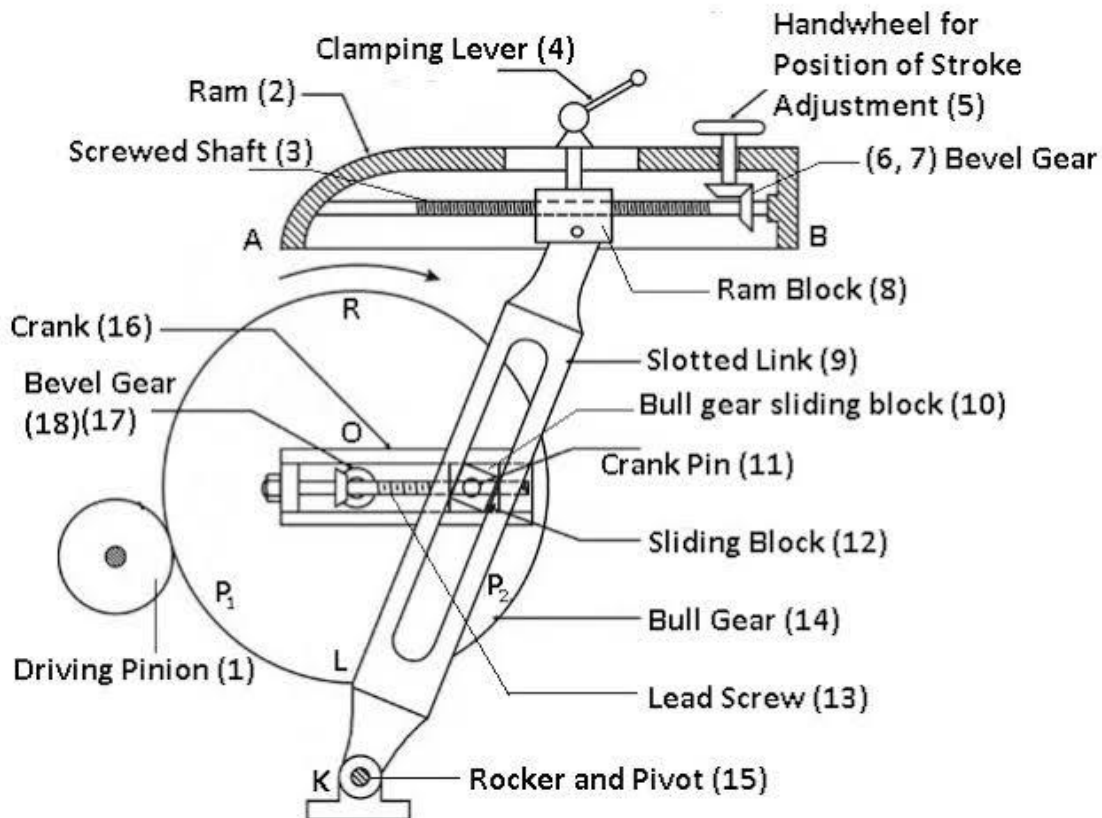

The radial slide is bolted to the centre of the bull gear. This radial slide carries a sliding block into which the crank pin is fitted.

As the bull gear will rotate, the crank will revolve at uniform speed. The sliding block which is mounted upon the crank pin is fitted upon the crank pin is fitted within the slotted link.

This slotted link is pivoted upon at its bottom end attached to the frame of column. The upper end of the sliding link is bifurcated and attached to the ram block by a pin. When the bull gear rotates, the crank pin revolves at a uniform speed.

The sliding block fastened to the crank pin will rotate on the crank pin circle and at the same time this slider will slide up and down in the sliding link.

As the slider will move inside the sliding link, it will provide a rocking movement to the sliding link and this movement will be transferred to the ram providing it a reciprocating motion. Hence the rotary motion of the bull gear is converted into reciprocating motion of ram.

Specification of a shaper machine:-

The specification of shaper machine depends upon the following:

- The maximum length of stroke of ram.
- Types of the drive (Crank, Gear and Hydraulic type)
- Power input of the machine.
- Floor space required to establish the machine.
- Weight of the machine in tonne.
- Feed
- Cutting to return stroke ratio.
- Angular movement of the table

SHORT QUESTIONS

1. Define shaper.

Ans:- The Shaper Machine is a reciprocating type of machine tool basically used to produce Horizontal. Vertical or Inclined fiat surfaces by means of straight-line reciprocating single-point cutting tools similar to those which is used in lathe operation.

2. Write the parts of shaper.

Ans:- base, column, cross rail, saddle, table, tool head.

3. What are application of shaper ?

Ans:- .

Make internal splines.

Make gear teeth.

To make dovetail slides.

Make key ways in gears

LONG QUESTIONS

1. Explain the working of shaper with neat sketch.

2. Explain the quick return mechanism with neat sketch.

3. Explain automatic table feed mechanism of a shaper.

4. Explain tool head of a shaper with net sketch.

CHAPTER—05

PLANNING MACHINE

Introduction:-

- The planer or planning machine is a machine tool, which like the shaper produces flat surfaces in horizontal, vertical or inclined plane.
- The fundamental difference is that the planer operates with an action opposite to that of the shapers, i.e., the work piece reciprocates past one or more stationary single point cutting tools.
- Planners are meant for machining large sized work pieces, which cannot be machined by the shaping machines.
- The work table is moved back and forth on the bed beneath the cutting head either by mechanical means, such as a rack and pinion gear or by a hydraulic cylinder.

5.1 Application of planner:-

- Cutting slots and grooves.
- Generating accurate flat and curved surfaces.
- Cutting at an angle and machining dovetails.

Difference between planner and shaper:-

<u>Planner</u>	<u>Shaper</u>
1. In a planner machine, the tool is stationary and work piece travels back and forth under the tool.	1. In a shaper machine work is held stationary and the cutting tool on the ram is moved back and forth across the work
2. A planner is meant for larger jobs than can be undertaken on a shaper	2. Shaper can be used for shaping much smaller job.
3. A planner is a heavy duty machine	3. A shaper is a light machine.
4. Planner can employ heavier cuts and coarse feed.	4. Shaper can employ light cuts and finer feed.
5. Planner uses several tools to cut simultaneously.	5. Shaper can use one cutting tool at a time.
6. The drive on the planner table either by gears or by hydraulics.	6. The shaper is driven using quick return mechanism.
7. Due to better rigidity of planner machine, compared to that of a shaper, planner can give more accuracy on machined surface.	7. It is less rigid and less robust.

5.2 Major components of a planner machine:-

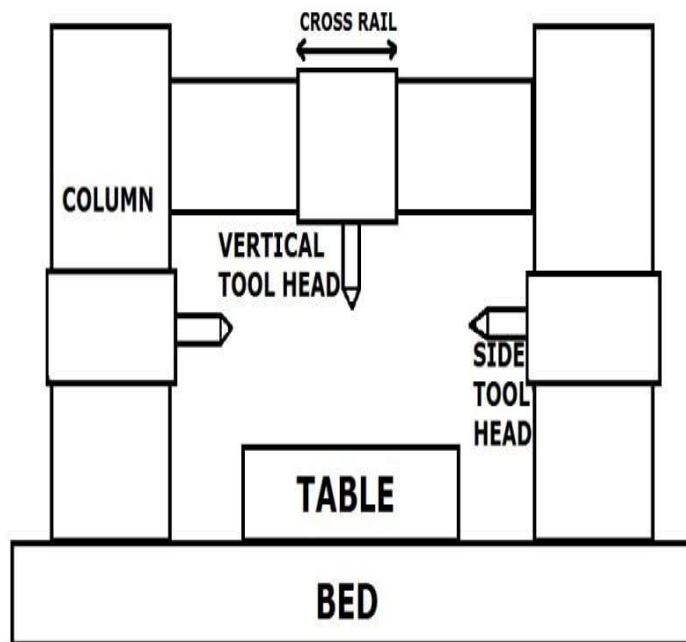

The major components of a planer machine are--

1. Bed:-

Bed of a planer is large in size and heavy in weight. It supports the column and all other moving parts of machine. It is made slightly longer than twice the length of the table may be moved on it. There is a v shaped ways on the bed which help to reciprocate or back and forth motion to the table.

2. Table:-

Table supports the work and reciprocates along the bed. Table is made from cast iron. The top face of the table is accurately finished in order to locate the work correctly. T- slots are provided on the entire length of the table so that the work and work holding devices may be bolted upon it.

3. Column:-

These are rigid box like vertical structure placed on each side of the bed and table. They are heavily ribbed to trace up severe force due to cutting. It also facilitate tool head mechanism. The cross rail may be made to slide up and down for accommodating different heights of work

4. Cross rail:-

- The Crossrail is a casting that connects the two housings. Cross rail provides rigidity to the machine.
- It occupies the face of the housing and can be clamped at the position by manual, hydraulic devices.
- The Cross rail when clamped should remain absolutely parallel to the top surface of the table, i.e. It must be horizontal irrespective of its position.
- Two tool heads are mounted which are called railhead. It has screws for vertical and crossfeed of the tool heads and a screw for elevating the rail. The planer screws can be operated by hand or power.

- **(5.4) 5. Tool head:-**

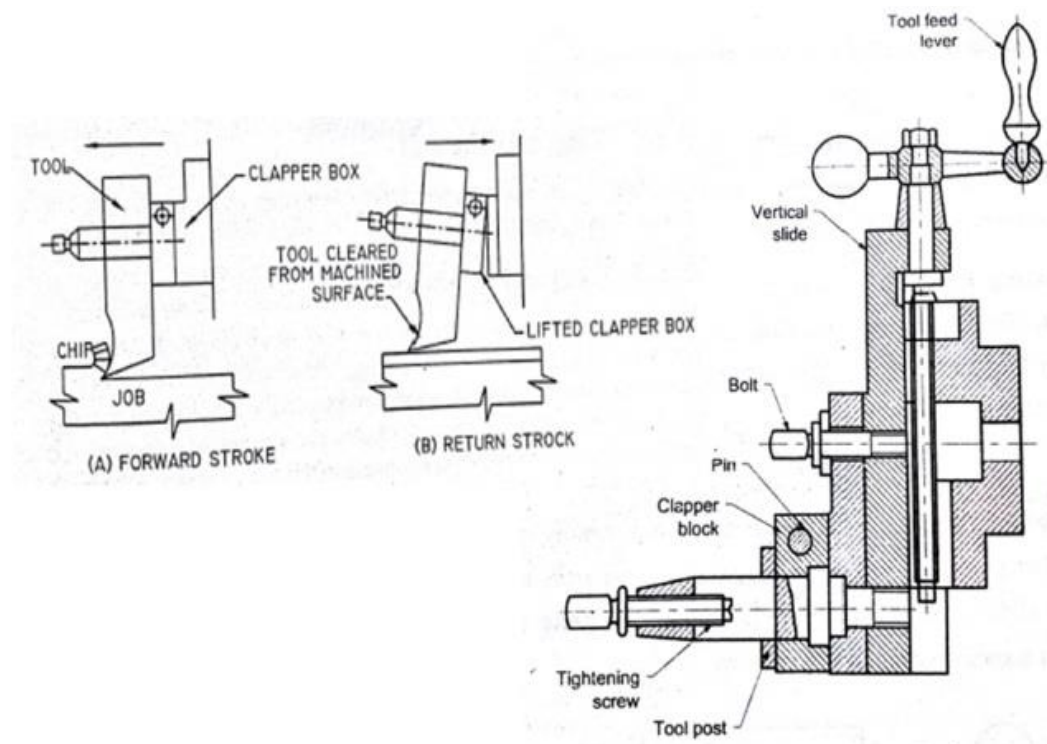

- The tool head of a planner is similar to that of a shaper both in construction and operation.
- Tool heads are mounted on the cross rail by a saddle.
- The saddle may be made to move transversely on the cross rail to give cross feed.
- The swivel base is pivoted on the saddle and is graduated on each side to 60°.
- The swivel base may be swivelled to any desired angle and the downfeed screw is rotated to feed the tool at that angle for machining angular surface.
- The vertical slide may be fed downwards by rotating the downfeed screw which passes through a nut fixed on the swivel base.
- The apron is clamped on the face of the vertical slide by clamping bolt and may be swiveled up to 20° on each side of the slide for giving the tool clearance while machining vertical surface.
- The clapper block is hinged to the clapper box, and it holds the tool post in which the tool is clamped by straps.
- During return stroke the tool head is lifted upward by clapper block to prevent the cutting edge from dragging on the work.
- The tool head is fed crosswise by rotating the crossfeed screw within the crossrail which passes through a nut attached to the saddle.
- Vertical slide holding the tool may be fed up or down by rotating the feed screw within the crossrail and the motion is transmitted to the downfeed screw through bevel gears.

5.3 Table drive mechanism:-

- This mechanism is used in a small size planer.
- The table drive mechanism also known as open and cross belt drive mechanism.

- loose pulleys are fixed. By shifting the belt from loose to fast pulley the machine is

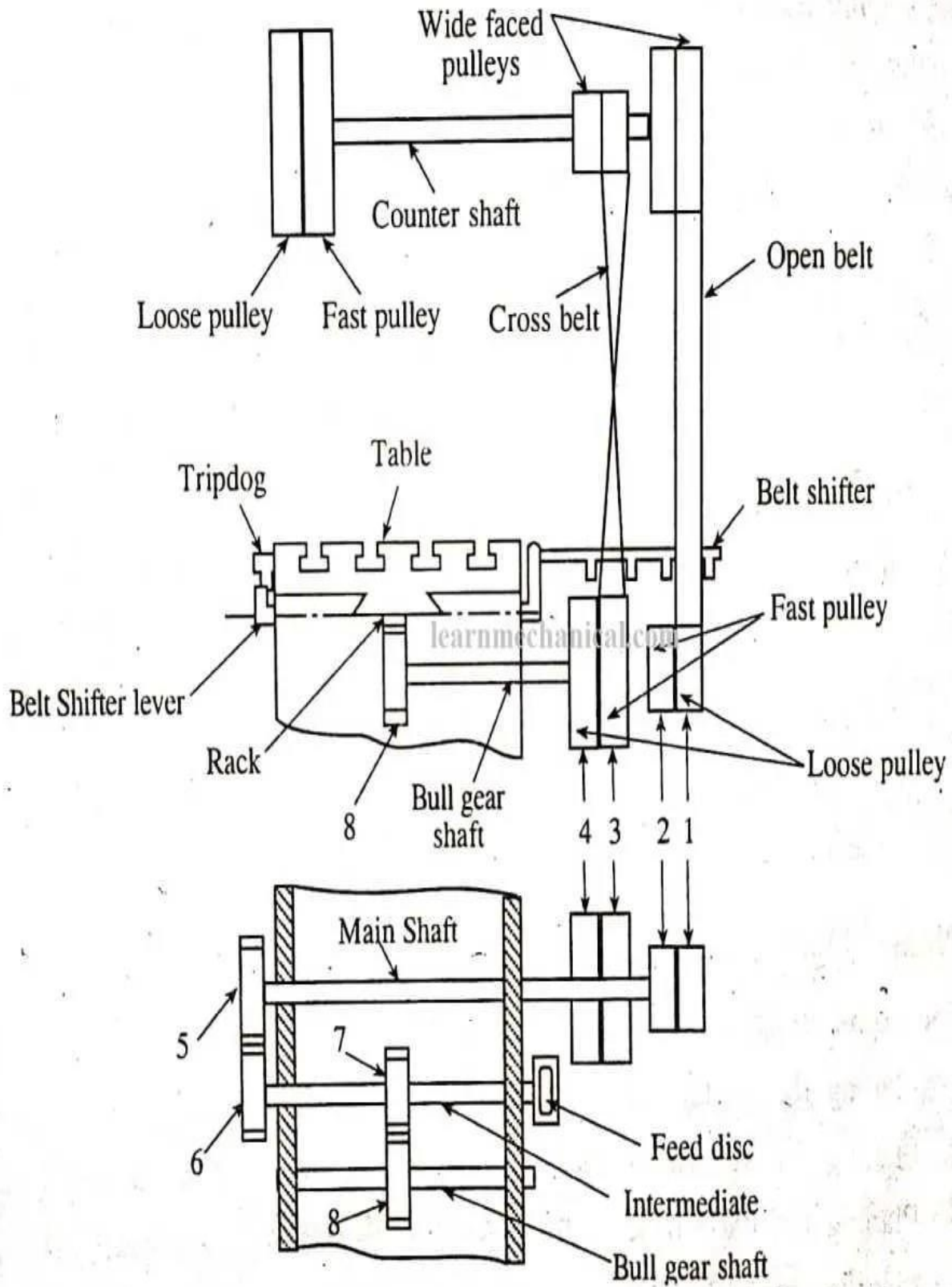

Quick return mechanism of a planer by open and crossbelt

- started or by shifting the belt from fast to loose pulley the machine can be stopped.
- The small diameter pulley drivers the crossed belt and large diameter pulley drivers the open belt.
 - The crossed belt further connects to the larger diameter pulleys 3(loose pulley) and 4(fast pulley) which are keyed to the main shaft of the table and the open belt connects the smaller diameter pulleys 1 (loose pulley) and 2(fast pulley) on the main shaft.
 - When the counter shaft rotates the motion will be transmitted to the main shaft of the table through fast pulleys of the cross or open belt and no motion will be transmitted when the belt is on loose pulley.
 - The motion of the main shaft is transmitted through gear 5, 6 and 7 to the bull gear 8. The bull gear meshes with a rack at the underside of the table, which converts the rotary motion to linear motion thereby table starts reciprocating.
 - The crossed belt is used for driving the table during a cutting stroke, which gives greater power and less speed by having the greater power and the speed is reduced as the belt connects smaller pulley on the countershaft to the larger pulley (3) on the main shaft of the table.
 - At the end of the forward cutting stroke. The trip dog mounted on the side of the planer table operates a belt shifter through a lever arrangement, thereby shifting the crossed belt from fast pulley (1) to loose pulley(2).
 - The motion is now transmitted from the larger pulley on the countershaft to the fast pulley on the main shaft and no motion is transmitted by crossed belt to the main shaft.
 - When the shaft receives the motion from an open belt, the direction of rotation of the shaft reversed and table starts moving to perform return stroke with a high speed as the open belt connects the larger diameter pulley on the countershaft with the smaller diameter pulley on the main shaft and thus obtaining the quick return motion.

5.5 Clamping of work:-

Clamping devices use for holding work piece on a planner.

1. Angle plates and step block
2. Adjustable block and T- slot clamp
3. Planner jacks
4. Clamps and T-bolts
5. V-block

1. Angle plates and step blocks:-

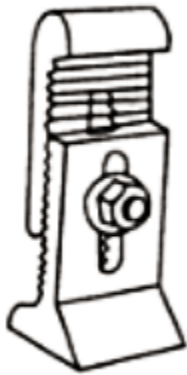

Adjustable block

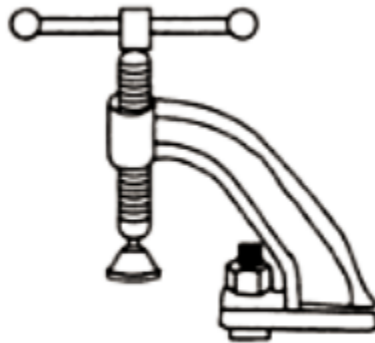

T-slot clamp

Angle plate is an L-shaped piece of cast iron or steel accurately machined to an angle of 90° .

For milling certain shapes of work piece can be mounted on the angle plate as a work holding device; the angle plate is then bolted to the machine table.

A step block used for holding mechanism by the help of T-bolts. One end of step block is set on work with the other end support on planer table by facilitate of bolts.

2. Adjustable block and T-slot clamps:-



Adjustable block

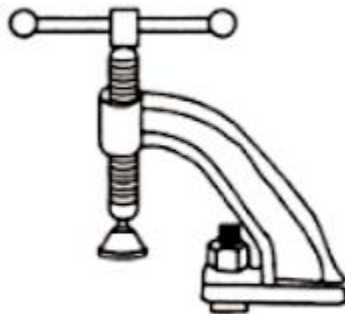

T-slot clamp

Adjustable block consists of two jagged jaws by grooves inside. An additional kind of clamp generally use is a T-slot clamp. Bolt of a T-slot clamp is strongly bolted to table and job on table for functioning the planning process.

3. Planer jack:-



Planer jacks are used for supporting work piece with leveling it on table.

Generally use planer jacks are-

- a. Bracing jack
- b. Standard planer jack
- c. Vertical jack

4. Clamps and T-bolts:-

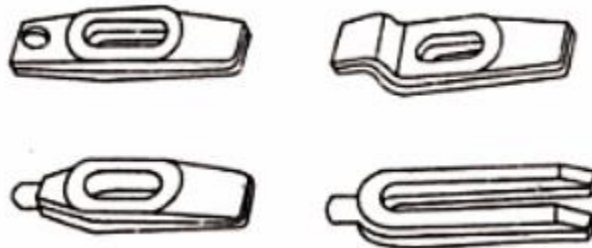

Generally use way of holding job directly to table is to use clamps. There are numerous designs of clamps accessible with some trendy ones.

5.V-blocks:-

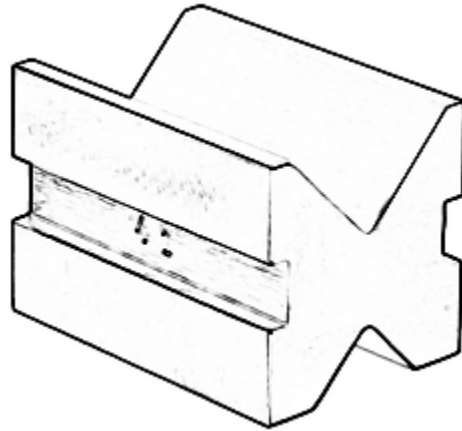

V-blocks are used in certain milling operations to hold round work. They should be made or purchased in pairs, so that one can be placed under each end of bug work. They are made with or without clamps.

POSSIBLE QUESTIONS SHORT QUESTION

1. Define planner.

Ans:- The planer or planning machine is a machine tool, which like the shaper produces flat surfaces in horizontal, vertical or inclined plane.

2. Write the parts of planner. Ans :- bed, column, table, cross rail, tool head.

3. What are the clamping devices used in planner?

Ans:- Angle plates and step block Adjustable block and T- slot clamp Planner jacks
Clamps and T-bolts V-block

1. Explain with neat sketch the working of a planner machine.

2. Explain the table drive mechanism with neat sketch.

3. Write and explain with neat sketch the clamping devices of a planner.

CHAPTER-06

MILLING MACHINE

Introduction:-

- In this **machine**, a multipoint cutter is rotating against the workpiece and material removed from the workpiece accordingly.
- The milling is a process of metal-removing by feeding the workpiece passes through the rotating multipoint cutter.

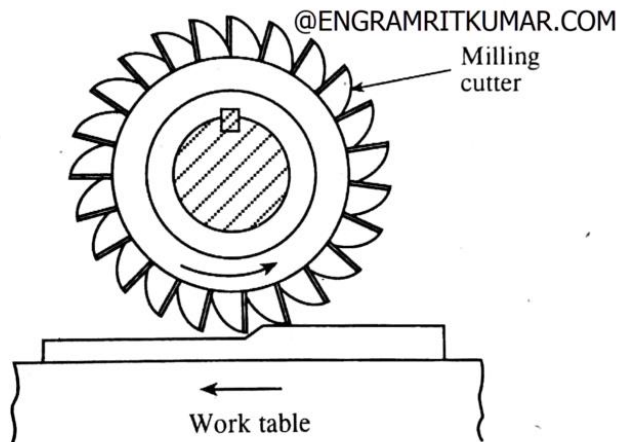

- This machine can hold one or more number of cutters at a time and rotates at high speed to remove the metal at a faster rate.
- The metal removal rate is faster as compared to a lathe Machine.
- This machine is used to make gears like Spur gears, and also drill the workpiece bore, and produce slots.

Main parts of milling Machine:-

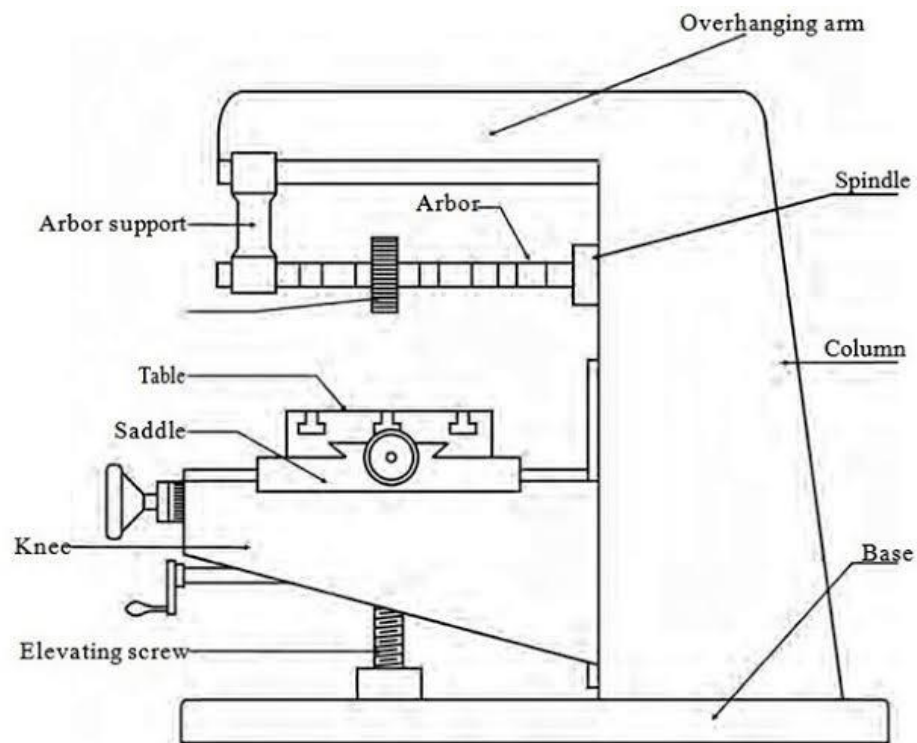

A milling machine consists of the following parts:

- Base
- Column
- Knee
- Saddle
- Table
- Overhanging Arm
- Spindle
- Arbor
- Arbor Supports
- Milling Head
- Ram

Base:-

- It is the foundation part of a machine and all other parts are joined on it.
- It carries the entire load so it should have high compressive strength and it is made up of cast iron.

Column:-

- It is mounted vertically on the base.
- It supports the knee, table, etc. and work as housing for all the other driving member.
- The column is a hollow member which contains driving gears and sometimes motor for the spindle and the table.

Knee:-

- It is a casting that supports the saddle and table.
- All gearing mechanism is enclosed within the knee.
- It is fastened to the column by dovetail ways.
- The knee is supported and adjusted by a vertical positioning screw (elevating screw).
- The elevating screw is used to adjust the knee up and down by raising or lowering the lever either with the help of hand or power feed.

Saddle:-

- This is placed between the table and the knee, and work as an intermediate part between them.
- This can moves transversally to the column face.
- This slides over the guideways provided situated on the knee which is perpendicular to the column face.
- The main function is to provide motion in a horizontal direction to the workpiece.
- This is also made by cast iron.

Table:-

- This is a rectangular casting which is present on the top of the saddle.
- The table is situated over the knee.
- It is the part of a machine that holds the workpiece while machining.
- This is made by cast iron and has T-slot cut over it.
- This provides vertical motion by moving the knee up and down.
- It provides horizontal motion by the feed screw.
- This provides a horizontal (transverse) motion by moving the saddle.

Overhanging arm:-

- The overarm is used to fastened arbor support.
- It may consist of one or two cylindrical bars that slide through the holes in the column.
- It is made by cast iron.

Spindle:-

- The spindle is the main part of the machine which holds the tool in the right place.
- This spindle provides the drive for arbors, cutters, and attachments used on a machine.

Arbor:-

- This is a mechanical part, which is used as an extension part of the spindle in a horizontal mill machine.
- It is fitted on the spindle whenever it's required.
- This holds the tool and moves it in the correct direction.

Arbor support:-

There are generally two types of arbor supports used in the milling machine.

- The first one has a small diameter bearing hole, 1-inch in maximum diameter, and the other one has a large diameter bearing hole, usually up to 23/4 inches.
- The arbor support has an oil reservoir that lubricates the bearing surfaces.
- It can be clamped anywhere on the overarm.
- The arbor support is used only in the horizontal types of milling machines.

Milling head:-

- It is the upper section of a vertical mill machine.
- It consists of a spindle, driving motor and other controlling mechanisms.

Ram:-

- One end of the arm is attached to the column and other ends to the milling head.
- The ram can be moved transversally (in and out) on the column by a hand lever.

(6.1) Types of milling machine and operation performed by:-

The milling machines are classified into following types-

1. Column and knee type milling machine
2. Hand milling machine
3. Plain milling machine
4. Universal milling machine
5. Omniversal milling machine
6. Vertical milling machine
7. Manufacturing or fixed bed type milling machine
8. Planner type milling machine
9. Special type milling machine

Milling machine operations:-

The following are the different operations performed in a milling machine:

1. Plain milling:-

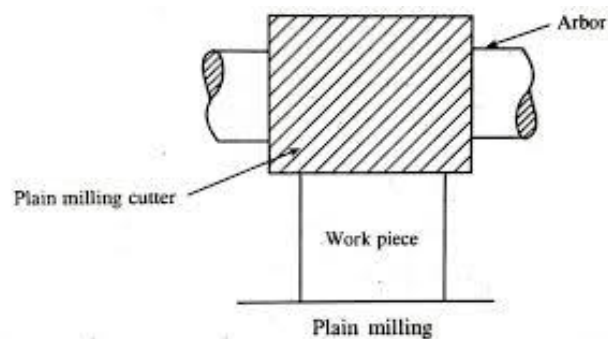

- The plain milling is the operation of production of a plain, flat, horizontal surface parallel to the axis of rotation of a plain milling cutter.

- The operation is also called slab milling. To perform the operation, the work and the cutter are secured properly on the machine.
- The depth of cut is adjusted by rotating the vertical feed screw of the table and the machine is started after selecting proper speed and feed.

2. Face milling:-

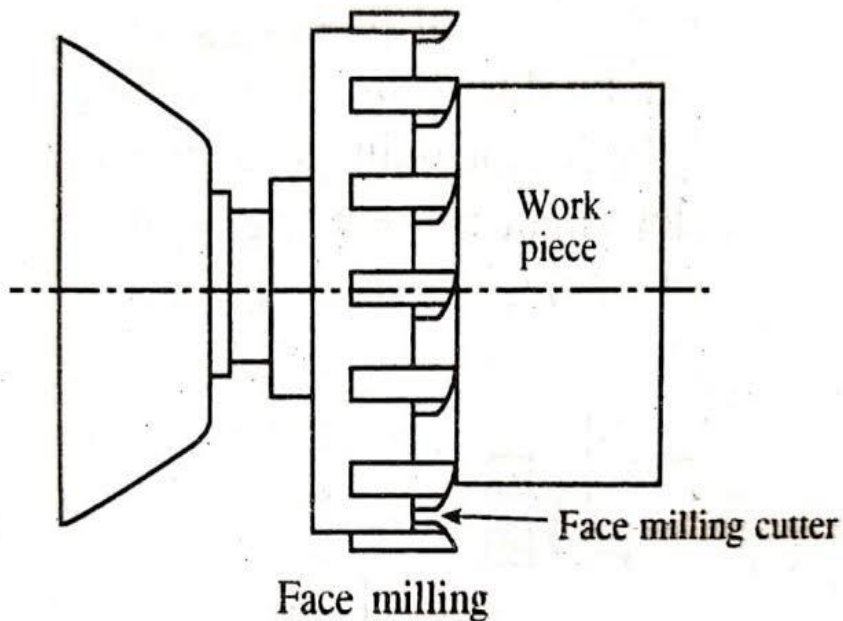

- The face milling operation is performed by a face milling cutter rotated about an axis perpendicular to the work surface.
- The operation is carried in a plain milling machine, and the cutter is mounted on a stub arbor to produce a flat surface.
- The depth of cut is adjusted by rotating the cross feed screw of the table.

3. Side milling:-

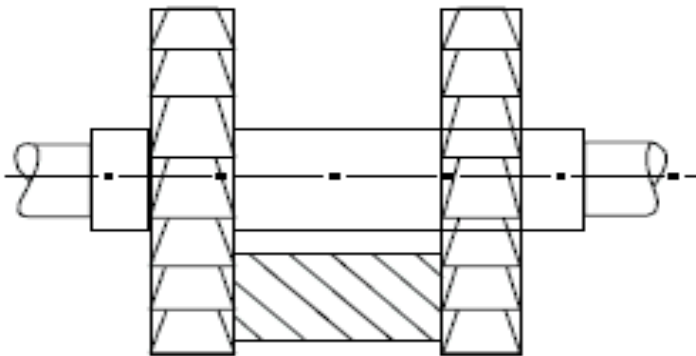

(c) Side milling

- The side milling is the operation of production of a flat vertical surface on the side of a work piece by using side milling cutter.
- The depth of cut is adjusted by rotating the vertical feed screw of the table.

4. Straddle milling:-

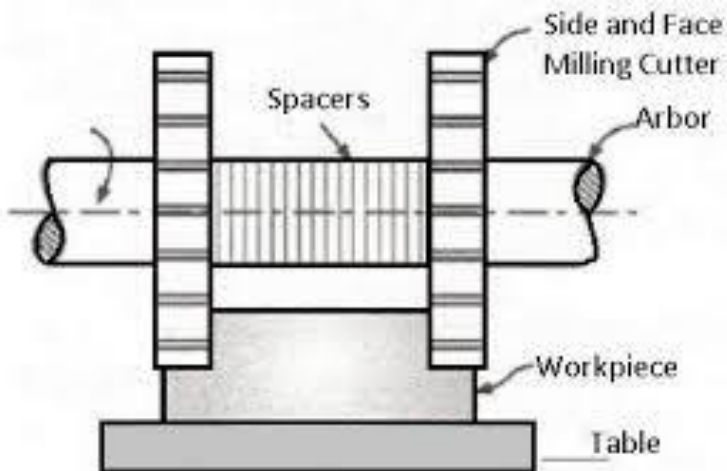

Straddle Milling Operation

- The straddle is the operation of production of flat vertical surfaces on both sides of a workpiece by using two side milling cutters mounted on the same arbor.
- The distance between the two cutter is correctly adjusted by using suitable spacing collars.
- The straddle milling is very commonly used to produce hexagonal surface.

5. Angular milling:-

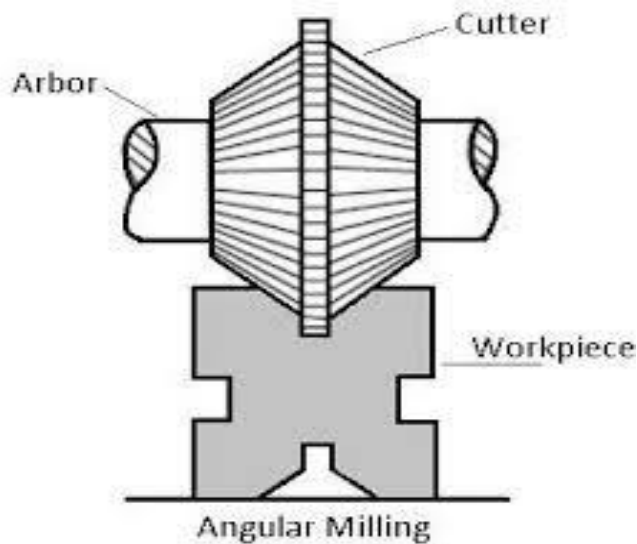

- The angular milling is the operation of production of an angular surface on a workpiece other than at right angles to the axis of the milling machine spindle.
- The angular groove may be single or double angle and may be of varying included angle according to the type and shape of the angular milling is the production of V-blocks.

6. Gang milling:-

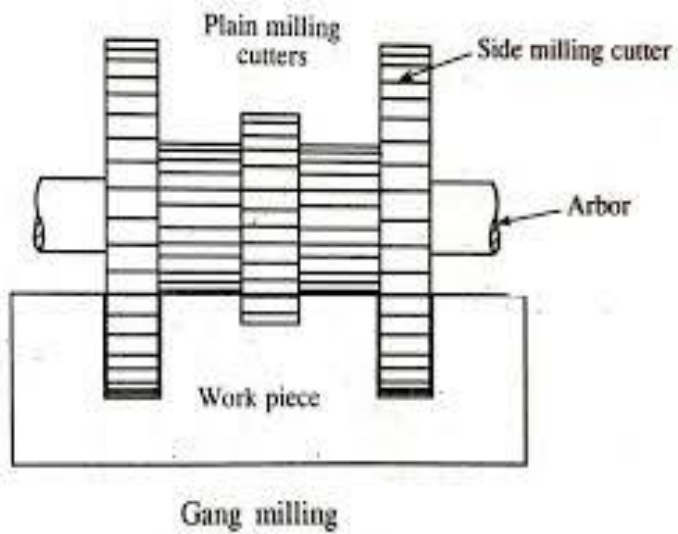

- The gang milling is the operation of machining several surfaces of a work piece simultaneously by feeding the table against a number of cutters having same or different diameters mounted on the arbor of the machine.
- The method saves much of machining time and is widely used in repetitive work.
- The cutting speed of a gang cutter is calculated from the cutter of the largest diameter.

7. Form milling:-

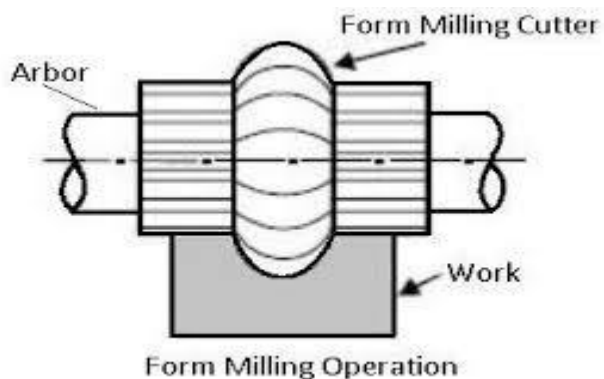

- The form milling is the operation of production of irregular contours by using form cutter.
- The irregular contour may be convex, concave, or any other shape.
- After machining, the formed surface is checked by a template gauge.
- The cutting speed for form milling is 20% to 30% less than that of the plain milling.

8. Profile milling:-

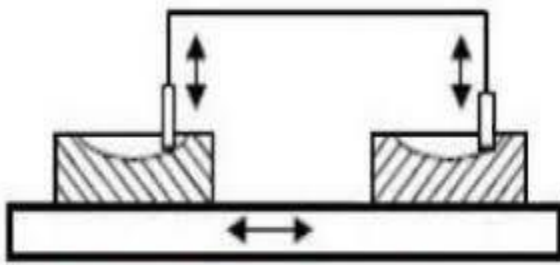

Profile Milling Operation

- The profile milling is the operation of production of an outline of a template or complex shape of a master die on a workpiece.
- Different cutters may be used for profile milling.
- An end mill is one of the most widely used milling cutter in profile milling work.

9. Gear cutting:-

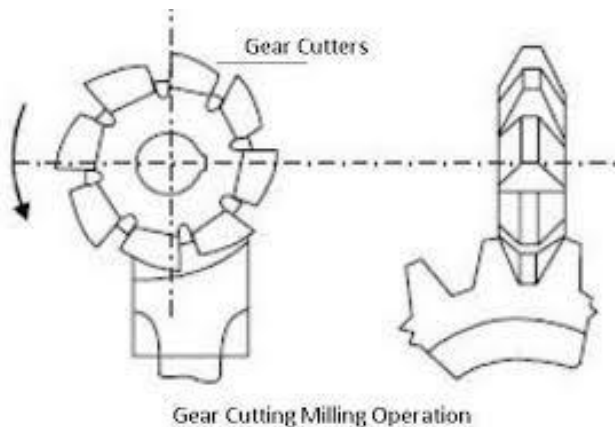

- The gear cutting operation is performed in a milling machine by using a form relieved cutter. The cutter may be cylindrical type or end mill type.
- The cutter profile corresponds exactly with the tooth space of the gear.
- Equally spaced gear teeth are cut on a gear blank by holding the work on a universal dividing head and then indexing it.

10. Thread milling:-

Thread Milling

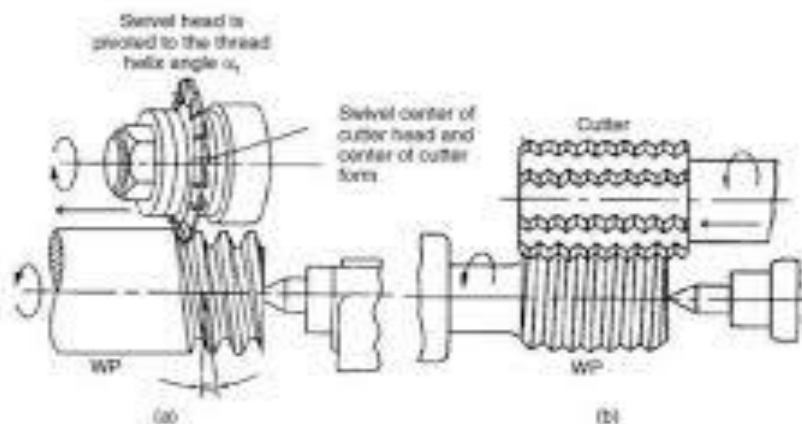

Single-form and multiple form milling cutter thread milling operations: (a) disc cutter and (b) multiple-thread cutter

- The thread milling is the operation of production of threads by using a single or multiple thread milling cutter.
- When the thread is cut by a multiple thread milling cutter, the cutter axis and the work spindle are set parallel to each other after adjusting the depth of cut equal to the full depth of the thread.
- The thread is completed by simply feeding the revolving cutter longitudinally through a distance equal to the pitch of the thread while the work is rotated through one complete revolution.

Types of CNC milling machine:-

CNC Milling Machines are machine operated cutting tools that are programmed and managed by Computer Numerical Control (CNC) systems to accurately remove materials from a workpiece. The end result of the machining process is a specific part or product that is created using a Computer Aided Design (CAD) software.

There are various types milling machines are used in industries :

1. Horizontal milling machine
2. Vertical milling Machine
3. Bed mill
4. Traveling column
5. Double column
6. C-frame
7. Double spindle
8. Five axis machining centre

(6.2) Work holding attachments:-

It is necessary that the work should be properly and securely held on the milling machine table for effective machining operations. The following are the usual method of holding work on the table.

1. T-bolts and clamps:-

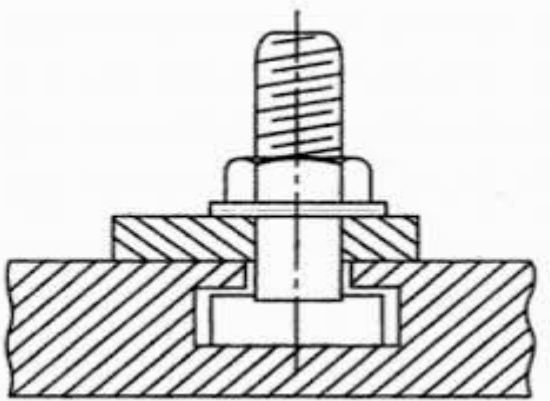

Bulky workpieces of irregular shapes are clamped directly on the milling machine table by using T-bolts and clamps. Different designs of clamps are for different patterns of work.

2. Angle plates:-

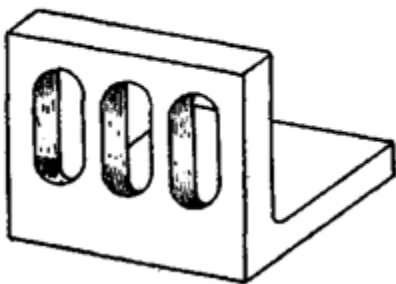

When work surfaces are to be milled at right angles to another face, angle plates are used for supporting the work. The angle plate is bolted on the table and the workpiece is supported on its face by bolts and clamps. A tilting type angle plate in which one face can be adjusted relative to the another for milling at a required angle is also sometimes used.

3. V-blocks:-

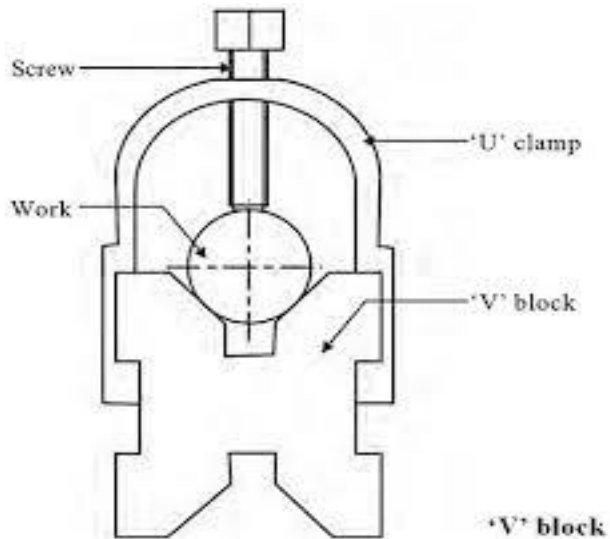

The V-blocks are used for holding shafts on milling machine table in which keyways, slots and flats are to be milled. The blocks are clamped on the machine table by straps and bolts. V-blocks are provided with a tongue at its base which fits into the T-slot of the table and prevents the block from any sideways movements.

4. Vises:-

Vises are the most common appliances for holding work on milling machine table due to its quick loading and unloading arrangement. There are mainly three types of vises commonly used in milling machines. They are plain vise, swivel vise, and tool makers universal vise.

(a) Plain vise:-

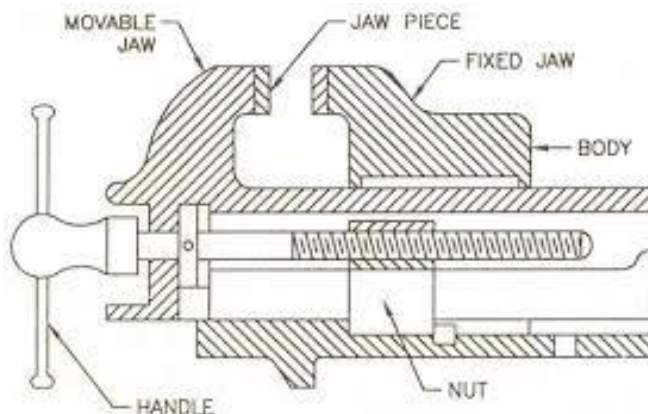

The plain vise bolted directly on the milling machine table is the most common type of machine vise used for plain milling machine vise used for plain milling operations. The vise may be fastened to the table with the jaws set either parallel or at right angles to the table T-slots. Work is clamped between the fixed and movable jaw and for holding workpieces of irregular shape special jaws are sometimes used.

(b) Swivel vise:-



The swivel vise is used to mill an angular surface in relation to a straight surface without removing the work from the vise. In construction, it may be considered as a plain vise which is mounted on a circular base graduated in degrees. The base is clamped on the table by means of T-slots.

(c) Tool maker universal vise:-

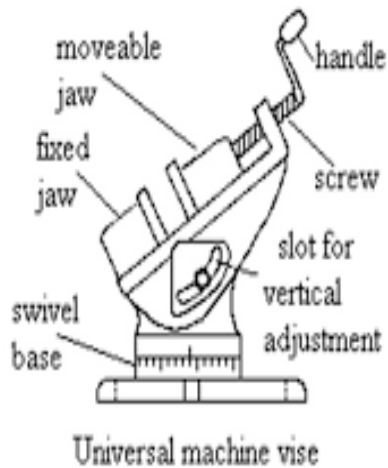

The universal vise can be swivelled in a horizontal plane similar to a swivel vise and can also be tilted in any vertical position for angular cuts. The vise not being rigid in construction is used mainly in tool room work.

5. Special fixtures:-

The fixtures are special designed to hold work for specific operation more efficiently than standard work holding device. Fixtures are specially useful when large numbers of identical parts are being produced. By using fixtures loading, locating, clamping and unloading time is greatly minimized.

Indexing or dividing head:-

The indexing is the operation of dividing the periphery of a work into any number of equal parts. In cutting spur gear, equal spacing of teeth on the gear blank is performed by indexing.

The indexing operations can also be adapted for producing hexagonal and square headed bolts, cutting splines on shafts, fluting drills, taps and reamers and many other jobs, all requiring the periphery of the workpiece to be divided equally and accurately.

The indexing is accomplished by using a special attachment known as dividing head or index head. The dividing heads are of three types (1) Plain or simple dividing head (2) Universal dividing head (3) Optical dividing head.

(6.3) 1.Plain or simple dividing head:-

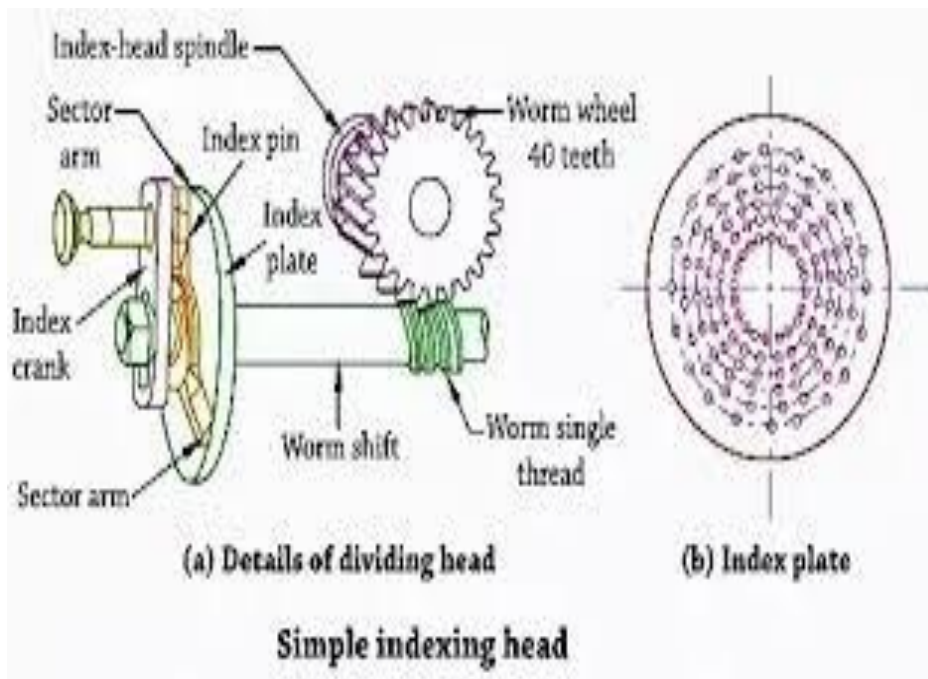

- The plain dividing head comprises of a cylindrical spindle housed in a frame, and a base bolted to the machine table.
- The index crank is connected to the tail end of the spindle directly, and the crank and the spindle rotate as one unit .The index plate is mounted on the spindle and rotates with it.
- The spindle may be rotated through the desired angle and then clamped by inserting the clamping lever pin into any one of the equally spaced holes or slots cut on the periphery of the index plate.
- The work is mounted at the nose end of the spindle by a Chuck or may be supported between the two centers.
- The tailstock is a separate assembly which is bolted to the machine table after aligning it's spindle axis with the dividing head spindle.
- This type of dividing head is used for handling large number of workpieces, which require a very small number of divisions on the periphery.

2. Universal dividing head:-

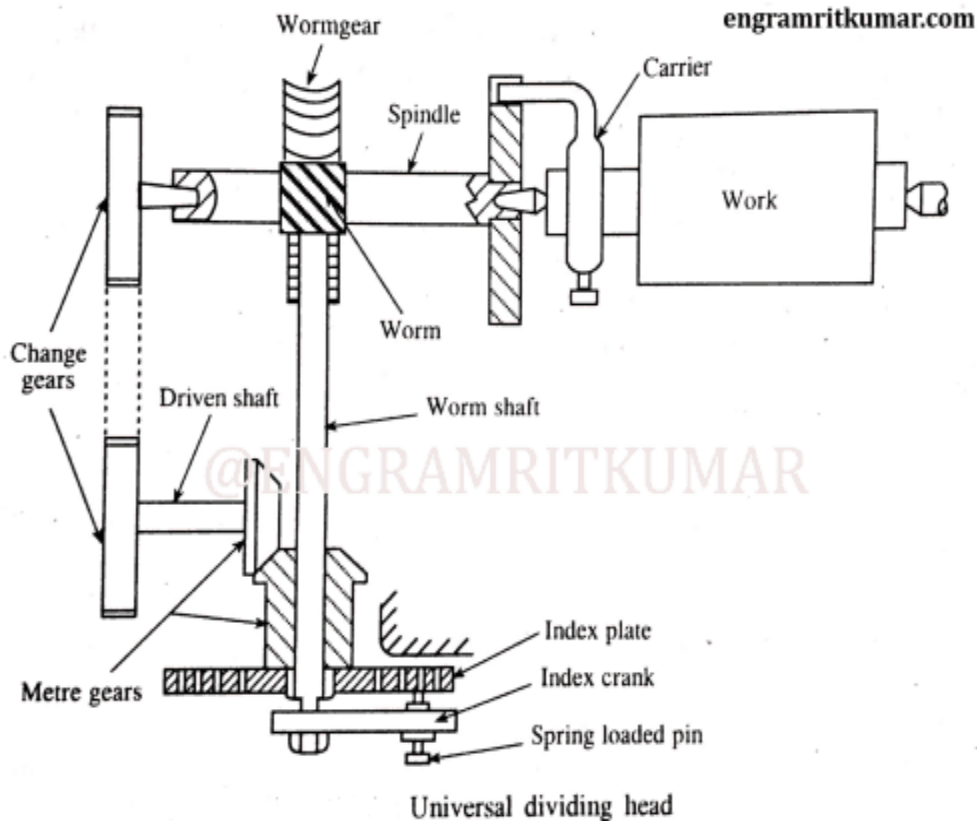

- A universal dividing head is used to indexing all forms of indexing.
- A universal dividing head is used for the following purposes:
 1. For setting the work in vertical, horizontal or in inclined positions, relative to the table surface.
 2. For turning the workpiece periodically through a given angle to impart indexing movement.
 3. For imparting a continuous rotary motion to the workpiece for milling helical grooves.

- The important parts of a universal dividing head are the worm and worm gear, index plate, sector arm, change gears and the spindle.
- The main spindle 5 housed on two accurate bearings carries a worm gear 4 is mounted on a shaft 10 at the other end of which a crank 13 is fitted.
- The worm gear 4 has 40 teeth and the worm 6 is single threaded. Thus 40 turns of the crank 13 will cause the spindle 5 to be rotated by $1/40$ of a revolution.
- In order to turn the crank 13 a fraction of a revolution, an index plate 12 is used. An index plate is a circular disc having a different number of equally spaced holes arranged in concentric circles.
- The index plate 12 is screwed on a sleeve which is loosely mounted on the worm shaft 10. Normally, the index plate 12 remains stationary by a lock pin 11 connected with the frame.
- A spring loaded pin 14 fixed to the crank 13 fits into the holes in the index 12.
- If the pin 14 is moved from one hole to the next hole in a 18 hole circle of the index plate, the spindle 5 will revolve $1/40 \times 1/18 = 1/720$ of a turn.
- The sector arms are used to eliminate the necessity of counting holes on the index plate each time the index crank is moved.
- The dividing head spindle 5 is provided with a taper hole at the nose to for accommodating a live centre. The nose is threaded on the outside for mounting a Chuck or a by

faceplate. The work 8 may be supported between the two centers 9 or on a Chuck.

- The spindle 5 is supported on a swivelling block which enables the spindle to be tilted through any angle from 5° below horizontal to 10° beyond vertical, and then clamped at that position.
- The dividing head spindle may be connected with the table feed screw through a train of gearing to impart a continuous rotary motion to the workpiece for helical milling.

(6.4) Procedure for simple indexing:-

In this case, different index plates with varying number of holes are used to increase the range of indexing. The index is fixed in position by a pin called lockpin. The spindle is then rotated by rotating the handle which is keyed to the worm-shaft as shown in Fig.

The following relation is used for simple indexing: $T = 40/N$, where T gives the number of turns or parts of a turn through which the index crank must be rotated to obtain the required number of divisions (N) on the job periphery.

Let us take an example of a gear blank on which 64 teeth are to be cut.

$$\text{Here } T = \frac{40}{N} = \frac{40}{24} = 1\frac{16}{24} \quad \text{or} \quad 1\frac{2}{3}$$

i.e., the worm is to be rotated by the handle through one complete rotation and two-third of the number of holes of any circle.

Procedure for compound indexing:-

The principle of operation of compound indexing is the same as that of simple indexing, but the only difference is that compound indexing uses two different circles of one plate and hence also sometimes referred to as hit and trial method.

- (i) By rotating the crank or handle in usual way keeping the index plate fixed.
- (ii) By releasing the back pin and then rotating the index plate with the handle.

For example, if a 27 teeth gear is to be cut, then $T = 40/27$ i.e., the rotation required for one tooth spacing is $40/27$ which may be written as $2/3 + 22/27$ or $12/18 + 22/27$.

So for each tooth, the worm will be rotated by 12 holes of 18 hole circle with the help of the crank and then the index plate is rotated by 22 holes of the 27 hole circle.

(6.5) Illustration of different indexing methods:-

The different types of indexing methods are-

Direct indexing:-

In this case, the dividing head has an index plate, fitted directly on the spindle. The intermediate use of worm and worm-wheel is avoided. The index plate has 24 holes and the periphery of job can be divided into 2, 3, 4, 6, 8 and 12 equal parts directly. This type indexing is most commonly used for indexing fixture.

Differential indexing:-

Available number of index plates with different hole circles, sometimes confine the range of plain indexing. In such cases, differential indexing is found to be more suitable. Between the indexing plate and spindle of dividing head, a certain set of the gears is incorporated extra. Dividing heads are provided with such standard set of gears.

During the differential indexing, the index-plate is unlocked and connected to a train of gears which receive their motion from the worm gear spindle. As the handle is turned, the index plate also turns, but at a different rate and perhaps in the opposite direction.

Differential indexing makes it possible to rotate the work by any fraction of revolution with the usual index plates furnished with the equipment.

Angular indexing:-

Instead of rotating the job through certain division on its periphery, sometimes it may be needed to rotate the job through certain angle. Angular indexing is used for this purpose. Since the crank and spindle ratio is 40 : 1 and hence when the crank moves through one revolution, the spindle or the job moves through 1/40 of revolution, i.e., the job will revolve through an angular movement of 9° .

Possible questions

Short questions

1. Define milling.

Answer:- Milling machines are very versatile. They are usually used to machine flat surfaces, but can also produce irregular surfaces. They can also be used to drill, bore, cut gears, and produce slots. The type of milling machine most commonly found in student shops is a vertical spindle machine with a swiveling head.

2. Write the parts of milling machine.

Answer:-

Base, column, knee, table, overhanging arm, spindle, Arbor.

3. Define indexing.

Answer:- The indexing is the operation of dividing the periphery of a piece of work into any number of equal parts. In cutting spur gear, equal spacing of teeth on the gear blank is performed by indexing.

4. Write the operations of milling machine.

Answer:- Various operations of milling machine are:

Plain milling, face milling, side milling, straddle milling, angular milling, gang milling, form milling, profile milling etc.

Long questions

1. Explain the operations of milling with neat sketch.

2. Explain compound indexing with neat sketch.

3. Describe the main parts of milling machine with neat sketch.

4. Write working of main parts of a milling machine with neat sketch.

5. Explain the methods are used for indexing.

CHAPTER-07

SLOTTER

Introduction:-

The slotting machine is a reciprocating machine tool in which, the ram holding the tool reciprocates in a vertical axis and the cutting action of the tool is only during the downward stroke.

(7.1) Major components of slotter:-

The major components of a slotter machine are:

1. Base
2. Column
3. Saddle
4. Cross-slide
5. Rotary table
6. Ram and Toolhead assembly
7. Ram drive mechanism
8. Feed mechanism

(7.2) Construction and working of slotter machine:-

Construction:-

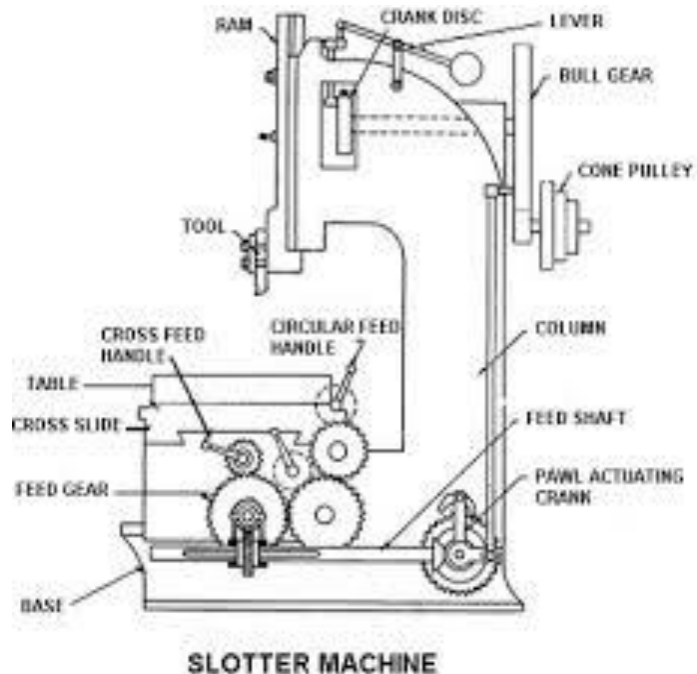

The slotter can be considered as a vertical shaper and its main parts are:

1. Base:-

The base is rigidly built to take up all the cutting forces and load of the machine. The top of the bed is accurately finished to provide guideways on which the saddle is mounted. The guideways are perpendicular to the column face.

2. Column:-

The column is the vertical member which is cast integral with the base and houses driving mechanism of the ram and feeding mechanism. The front vertical face of the column is accurately finished for providing ways on which the ram reciprocates.

3. Saddle:-

The saddle is mounted upon the guideways and may be moved toward or away from the column either by power or manual control to supply longitudinal feed to the work. The top of the saddle is accurately finished to provide guideways for the cross - slide. These guideways are perpendicular to the guideways on the base.

4. Cross-slide:-

It is mounted on the guideways of the saddle and can provide cross-feeding of the table.

- It holds the circular table.
- It provides the arrangement of cross-feeding either manually or by power.

5. Rotary table:-

- It can rotate on cross-slide to provide circular feeding of the work.
- It can hold the work by clamping, using fixtures, fixing vice, etc.
- It has the arrangement of rotary feeding either by hand or by power.
- On some machines, the table may be graduated in degrees for indexing.

6. Ram and Toolhead assembly:-

- The ram is the reciprocating member of the machine mounted on the guideways of the column.
- It supports the tool at its bottom end on a tool head
- A slot is cut on the body of the ram for changing the position of stroke.
- In some machines, special type of tool holders are provided to relieve the tool during its return stroke.

7. Ram drive mechanism:-

- A slotter removes metal during downward cutting stroke only where as during upward return stroke no metal is removed.
- To reduce the idle return time , quick return mechanism is incorporated in the machine.
- The usual types of ram drive mechanisms are:
 - a. Whitworth quick return mechanism
 - b. Variable speed reversible motor drive mechanism
 - c. Hydraulic drive mechanism

8. Feed mechanism:-

- It provides the arrangement of longitudinal and cross—a feed of the table either by power or manual.
- It also provides the arrangement of circular or rotary feeding of the table on a vertical axis.
- Intermittent feeding of the table is supplied at the beginning of each cutting or forward stroke of the ram.

Working:-

- The working of the Slotter machine is similar to the shaper machine do but the main difference between them is the Shaper machine works horizontally whereas Slotter machines work vertically.
- Now the ram is connected to the crank and crank connected to the gears. So what happened here is when we increase or decrease the gear speed, the rotation of crank increases and decreases. And as per these, the ram moves up and down.
- We have attached the workpiece into the work table and manually we bring the ram near to the workpiece and according to the ram we adjust the worktable and then we have to clamp it.
- Now we supply the power as per gear the crank rotates and the crank is connected to the ram so ram moves up and down.
- During down (ram moves down) the cutting stroke takes place and while moving up or return stroke there is no cut.
- If we have to cut at the different sections then manually we give feed to the work table and as per requirement, it cuts.

(7.3) Tools used in slotter:-

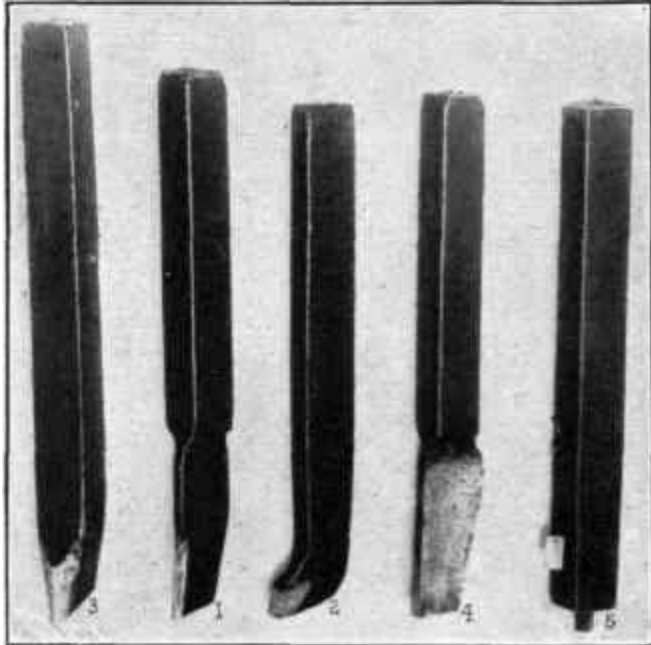

- A slotting machine tool differs widely from a shaper or a planer tool as the tool in a slotter removes metal during its vertical cutting stroke.
- This changed cutting condition presents a lot of difference in the tool shape.
- In a lathe, shaper or a planer tool the cutting pressure acts perpendicular to the tool length, whereas in a slotter the pressure acts along the length of the tool.
- The rake and clearance angle of a slotter tool apparently look different from a lathe or a shaper tool.
- Slotter tools are provided with the top rake, front clearance and side clearance, but no side rake is given.
- The nose of the tool projects slightly beyond the shank to provide clearance.

- The slotter tools are robust in cross-section and are usually of forged type ; of course, bit type tools fitted in heavy duty tool holders are also used.
- Keyway cutting tools are thinner at the cutting edges.
- Round nose tools are used for machining circular or contoured surfaces. Square nosed tools are used for machining flat surfaces.

Possible question

Short questions

1. Define slotter.

Answer:- The slotting machine is a reciprocating machine tool in which, the ram holding the tool reciprocates in a vertical axis and the cutting of the tool is only during the downward stroke.

2. Write the main parts of a slotter.

Answer:- Base, column, saddle, cross-slide, rotating table, ram and tool head assembly, ram drive mechanism, feed mechanism.

Long questions

1. Describe the main parts of a slotting machine with neat sketch.

2.Explain the work of slotting machine with neat sketch.

3.Describe various slotting tools.

CHAPTER-08

GRINDING

(8.1) Significance of grinding operation:-

- Grinding is metal cutting operation performed by means of a rotating abrasive wheel that acts as a tool.
- This is used to finish workpieces which must show a high surface quality, accuracy of shape and dimension.
- Mostly grinding is the finishing operation because it removes comparatively little metal, 0.25 to 0.50 mm in most operations and the accuracy is in the order of 0.000025 mm.
- Grinding is also done to machining materials which are too hard for other machining methods that use cutting tools.

(8.2) Manufacturing of grinding wheels:-

An abrasive is a substance that is used for grinding and polishing operations. It should be pure and have uniform physical properties of hardness, toughness, and resistance to fracture to be useful in manufacturing grinding wheels.

Abrasive may be classified in two principal groups:

1. Natural
2. Artificial or manufactured

1. Natural:-

The natural abrasives include the following materials:

- **Sandstone** is one of the natural abrasive stones from which grindstones are shaped. The quartz cutting agent is relatively shaft

that materials harder than quartz cannot be abraded or ground rapidly.

- **Emery** is a natural aluminium oxide. It contains from 55 to 65 percent aluminium, the remainder consist of iron oxide and other impurities.
- **Corundum** is a natural aluminium oxide also. It contains 75 to 95 percent aluminium oxide; the remainder consists impurities. Both emery and corundum have a greater hardness and better abrasive action than quartz.
- Diamonds of less than gem quality are crushed to produce abrasive grains for making grinding wheels to grind cemented carbide tools and to make lapping compound.

2. Artificial:-

Artificial or manufactured abrasives include chiefly silicon carbide and aluminium oxide.

Silicon carbide(SiC):-

- This abrasive is manufactured from 56 parts of silicon sand, 34 parts of powdered coke, 2 parts of salt, and 12 parts of saw dust in a long, rectangular electric furnace of the resistance type that is built up of loose brickwork.
- Sand furnishes silicon, coke furnishes carbon, sawdust makes the charge porous, salt helps to fuse it, and gases may escape through the open joints in the brickwork.
- It is used for grinding materials of low tensile strength such as cemented carbide, stone and ceramic materials, gray cast iron, brass, bronze, copper, aluminium, vulcanized rubber, etc.
- The abrasive wheels are denoted by 'S'.

Aluminium oxide (Al₂O₃):-

- This is manufactured by heating mineral bauxite, a hydrate aluminium oxide clay containing silica, iron oxide, titanium oxide, etc. mixed with ground coke and iron borings in a arc-type electric furnace.
- Aluminium oxide is tough and not easily fractured, so it is better adopted to grinding materials of high tensile strength, such as most steels, carbon steels, high speed steels, annealed malleable iron , wrought iron, tough bronzes.
- The wheels are denoted by 'A' .

(8.3) Criteria for selecting of grinding wheels:-

In selecting a grinding wheel there are four constant factors and four variables:

Constant factors

1. The material to be ground:-

This influences the selection of;

- (a) Abrasive (b) Grain size (c) Grade (d) Structure and (e) Bond
- (a) Aluminium oxide abrasive is recommended for materials of high tensile strength and silicon carbide for low tensile strength.
- (b) Fine grain is used for hard brittle materials and coarse grain for soft ductile material.
- (c) Hard wheel is used for soft materials and soft wheel for hard materials.
- (d) Generally, close spacing is required for hard and brittle materials and wide for soft and ductile.
- (e) The class of work usually dictates the bond to be used. Bond selection, of course, can be safely left to the manufacturers, if the

class of work for which the wheel is required is clearly stated. However, majority of wheels are manufactured with vitrified bonds.

2. Amount of stock to be removed:-

This involves accuracy and finish. Coarse grain is used for fast cutting and fine grain for fine finish; wide spacing for rapid removal and close for fine finish; resinoid, rubber, and shellac bond for high finish.

3. Area of contact:-

Area of contact influences the selection of grit size, grade and structure number.

Fine grain and close grain spacing are useful where the area of contact involved is small, and coarse grain and spacing are employed where a large area of contact is concerned.

4. Type of grinding machine:-

Type of grinding machine determines to an extent the grade of the wheel. Heavy rigidly constructed machines take softer wheels than the lighter more flexible types. The combination of speeds and feeds on some precision machines may affect the grade of wheel desirable for best results.

Variable factors

1. Wheel speed:-

The wheel speed influences the selection of grade and bond. The higher wheel speed with relation to work speed, the softer the wheel should be. Vitrified bond is usually specified for speeds upto 2000 s.m.p.m. and rubber, Shellac or resinoid bonds for speed over 2000 s.m.p.m.
(s.m.p.m-surface speed in meter per minute)

2. Work speed:-

The work speed with relation to the wheel speed determines the hardness of the wheel. The higher the work speed with relation to the wheel speed, the harder the wheel should be. Variable work speed are often provided on grinding machines to preserve the proper relative surface speeds between the work and wheel as the wheel diameter decreases because of wear.

3. Condition of the grinding machine:-

The condition of the grinding machine has a bearing on the grade of the wheel to be selected. Spindle loose in their bearings, and insecure foundations would necessitate the use of harder wheels than would be the case if the machine were in better operating condition.

4. Personal factor:-

The skill of workman variable factor which should be considered in selecting the wheel, as, for instance on off-hand grinding, it can vary the grinding cost considerably on the same work in the same factory.

(8.4) Specification of grinding wheel:-

- The Grinding Wheel use in end-finishing of the product. It consists abrasive grains bonded together using Resins, Epoxy, Rubber, Metal & Vitrified Glass Materials
- They can be simple, flat disc shape without any recesses, flaring and cups shaped.
- The type 1 wheels fall under this category and further designated to these types called "1A1", "1A8". Moreover, 1A1

and 1A8 are known for the straight super abrasives wheels having straight face and no recess.

- For example use a wheel marked A36-L5-V.
- The A refers to the abrasive material which is aluminum oxide.
The 36 represents the grain size.
The L shows the wheel grade or also called degree of hardness, which is medium.
The 5 refers to the structure of the wheel
And the V refers to the bond type.

Cylindrical grinder:-

Centre type grinders are intended primarily for grinding plain cylindrical parts, although they can also be used for grinding contoured cylinders, fillets, and even cams and crankshafts.

It is also named as plain center type grinder.

It is essentially a lathe on which a grinding wheel has been substituted for the single point tool. It consists of the following parts:

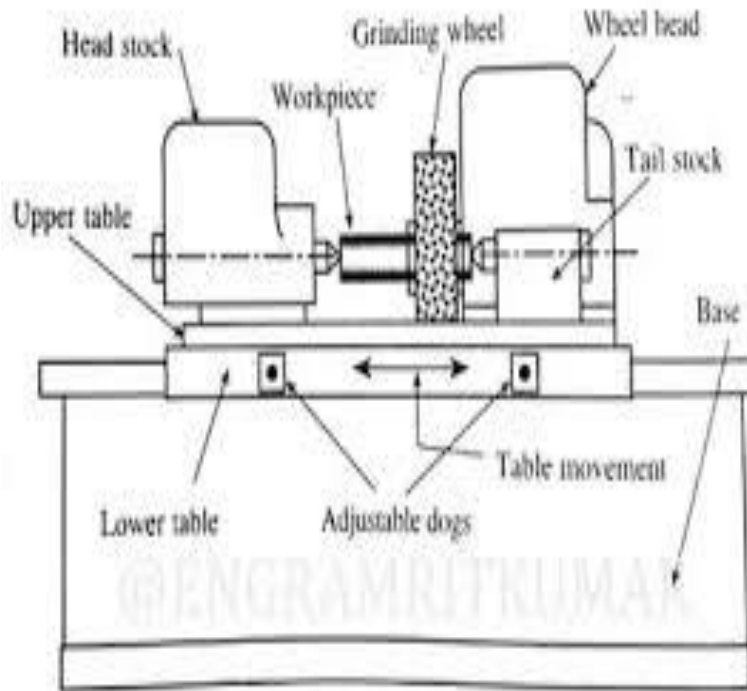

Plain cylindrical grinding machine

1. Base:-

The base or bed is the main casting that rests on the floor and supports the parts mounted on it. On the top of the base are precision horizontal ways set at right angles for the table to slide on. The base houses the table-drive mechanism.

2. Table:-

There are two tables, lower table and upper table. The lower table slides on ways on the bed provides traverse of the work past the grinding wheel. It can be moved by hand or power within desired limits.

3. Headstock:-

The headstock supports the workpiece by means of a dead center and drives it by means of a dog, or it may hold and drive the workpiece in a Chuck.

4. Tailstock:-

The tailstock can be adjusted and clamped in various positions to accommodate different lengths of workpiece.

5. Wheel head:-

The wheel head carries a grinding wheel and its driving motor is mounted on a slide at the top and rear of the base. The wheel head may be moved perpendicularly to the table ways, by hand or power, to feed the wheel to work.

6. Cross feed:-

The grinding wheel is fed to the work by hand or power as determined by the arrangement of the cross-feed control lever. On plain grinding machines, the operation may be stopped automatically when the workpiece has been finished to size. In one method it uses an automatic caliper type gauging attachment to measure the workpiece and stop the operation at the proper time.

Surface grinder:-

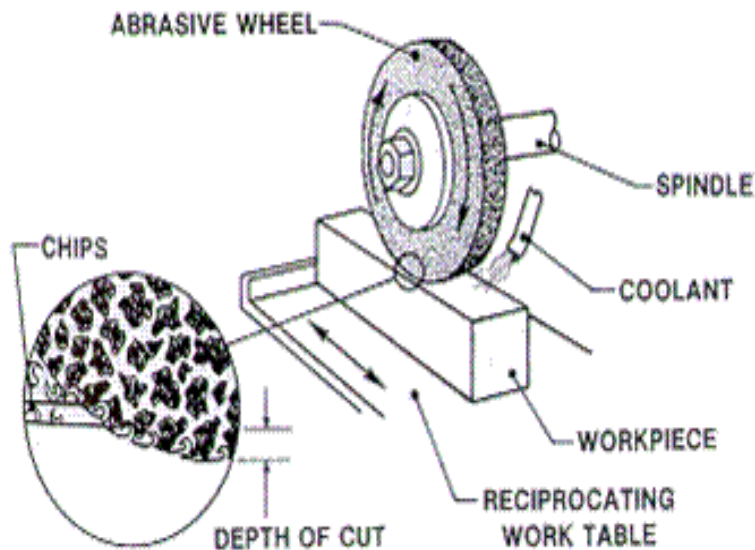

Fig.1 Elements of a grinding process

Surface grinding machines are employed to finish plane or flat surfaces. They are also capable of grinding irregular, curved, convex, and concave surfaces.

Conventional surface grinders may be divided into two classes: one class has reciprocating tables for work ground along straight lines, while the other covers the machine with rotating work tables for continuous rapid grinding.

Surface grinders may also be classified according to whether they have horizontal or vertical grinding wheel spindles.

The majority of surface grinders are of the horizontal table type. In the horizontal type of machine, grinding is normally done on the periphery of the wheel. The area of contact is small, and the speed is uniform over the grinding surface.

Small grain wheels can be used, and the finest finishes obtained.

In the vertical type, surface grinders apply the face or side of the wheel, and cupped, cylindrical, or segmented wheels are used.

The area of contact may be large, and stock can be removed rapidly.

Centre less grinder:-

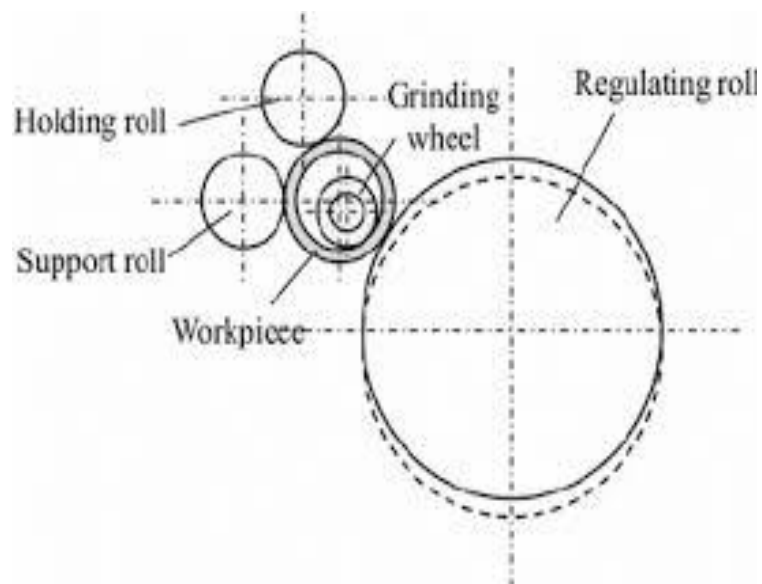

The external centerless grinding principle is also applied to internal grinding. In internal centerless grinding, the work is supported by three rolls. One is the regulating roll, and the other is a pressure roll to hold the workpiece firmly against the support and regulating rolls.

The grinding wheel contacts the inside diameter of the workpiece directly opposite the regulating roll, thus assuring a part of absolutely uniform thickness and concentricity. The pressure roll is mounted to swing aside to permit loading and unloading.

Possible questions

Short questions:-

1. Define grinding.

Answer:- Grinding is metal cutting operation performed by means of a rotating abrasive wheel that acts as a tool. This is used to finish workpieces which must show a high surface quality, accuracy of shape and dimension.

2. Write the materials used in manufacturing of Grinding wheels.

Answer:- Sand stone, emery, corundum, diamond, silicon carbide, aluminium oxide.

3. What are the criteria for selecting a grinding wheel?

Answer:- The material to be ground

Amount of stock to be removed

Area of contact

Type of grinding machine

Wheel speed

Work speed

Condition of the grinding wheel

Constant factor

4. Write the parts of Grinding machine.

Answer:- Base, table, headstock, tailstock, wheel head, cross feed.

5. Write the various types of Grinding machines.

Answer:- Cylindrical grinder, internal grinder, surface grinder, tool and cutter grinder, special type Grinding machines.

Long questions:-

1. Explain manufacturing of Grinding wheels.
2. State criteria for selecting of grinding wheels.
3. Write the specifications of Grinding wheel.
4. Explain the working of cylindrical grinder with neat sketch.
5. Explain the working of surface grinder with neat sketch.
6. Explain the working of center less grinder with neat sketch.

CHAPTER-09

INTERNAL MACHINING OPERATIONS

Introduction:-

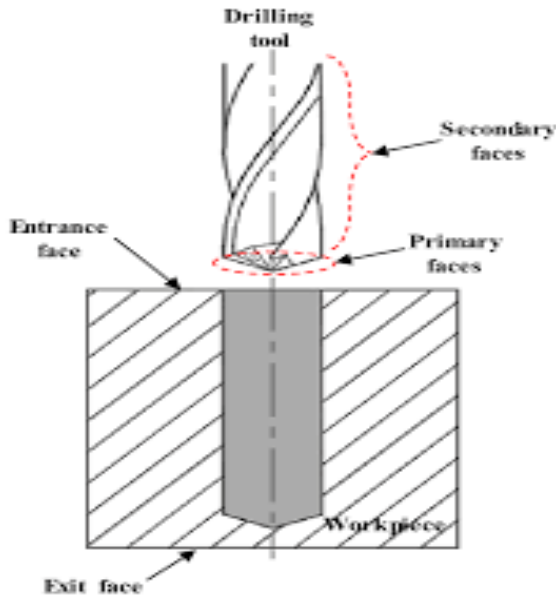

In a Drilling machine holes may be drilled quickly and at a low cost. The hole is generated by the rotating edge of a cutting tool known as the drill which exerts vertical on the work clamped on the table. As the machine tool exerts vertical pressure to originate a hole it is loosely called a “drill press”.

(9.1) Classification of drilling machine:-

The drilling machines are classified into following types-

1. Portable drilling machine

2. Sensitive drilling machine
 - a. Bench mounting
 - b. Floor mounting
3. Upright drilling machine
 - a. Round column section
 - b. Box column section
4. Radial drilling machine
 - a. Plain
 - b. Universal
 - c. Semiuniversal
5. Gang drilling machine
6. Multiple spindle drilling machine
7. Automatic drilling machine
8. Deep hole drilling machine
 - a. Vertical
 - b. Horizontal

Working of Bench drilling machine:-

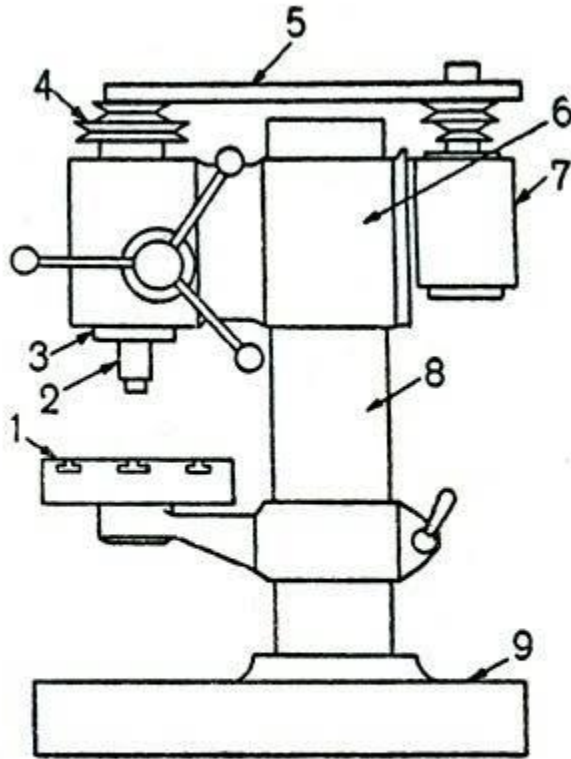

1. Table, 2. Vertical drill spindle, 3. Sleeve, 4. Cone pulley, 5. V-belt, 6. Head, 7. Driving motor, 8. Vertical column, 9. Base

- The bench drilling machine is a small machine designed for drilling a small hole at high speed in light jobs, the base of the machine may be mounted on a bench or on the floor.
- It consists of a vertical column, a horizontal table, a head supporting the motor and driving mechanism, and a vertical spindle for driving and rotating the drill.

- There is no arrangement for any automatic feed of the drill spindle.
- The drill is fed into the work by purely hand control. High speed and hand feed are necessary for drilling small holes.
- As the operator senses the cutting action, at any instant, it is called sensitive drilling machine.
- These drilling machines are capable of rotating drills of diameter 1.5 to 15.5 mm.
- Super sensitive drilling machines are designed to drill holes as small as 0.35 mm in diameter and the machine is rotated at a high speed of 20000 r.p.m or above.

Working of Pillar drilling machine:-

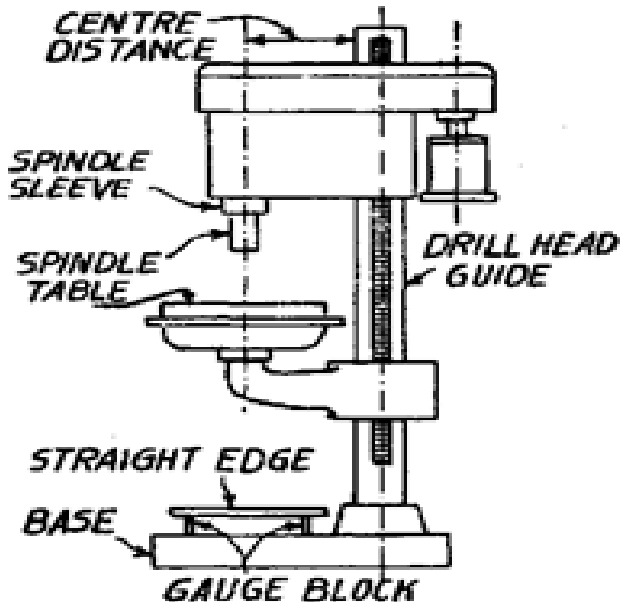

- The upright pillar drilling machine with box column section has the square table fitted on the slides at the front face of the machine column.
- Heavy box column gives the machine strength and rigidity.
- The table is raised or lowered by an elevating screw that gives additional support to the table.
- These special features permit the machine to work heavier workpieces, and holes more than 50 mm diameter can be drilled by it.

Working of Radial drilling machine:-

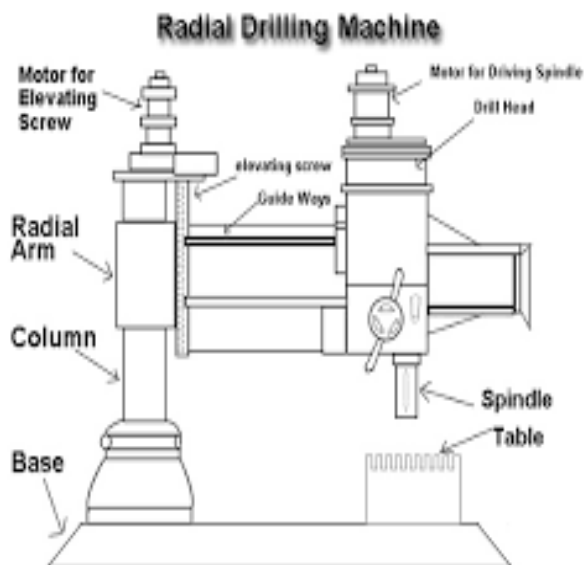

- The radial drilling machine is intended for drilling medium to large and heavy workpieces. The machine consists of a heavy, round, vertical column mounted on a large base.
- The column supports a radial arm which can be raised and lowered to accommodate workpieces of different heights.
- The arm be swung around to any position over the work bed.
- The drill head containing mechanism for rotating and feeding the drill is mounted on a radial arm and can be moved horizontally on the guideways and clamped at any desired position.
- These three movements in a radial drilling machine when combined together permit the drill to be located at any desired position on a large workpiece for drilling the hole.
- When several holes are drilled on a large workpiece, the position of the arm and the drill head is altered so that the drill spindle may be moved from one position to the other after drilling the hole without altering the setting of the work.
- This versatility of the machine allows it to work on large workpieces.

(9.2) Principle of Boring:-

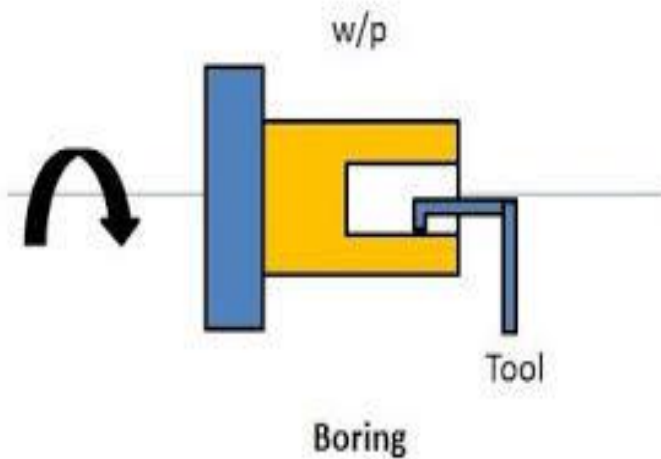

In machining, boring is the process of enlarging a hole that has already been drilled by means of a single-point cutting tool, such as in boring a gun barrel or an engine cylinder. Boring is used to achieve greater accuracy of the diameter of a hole, and can be used to cut a tapered hole.

The boring machines are classified as follows-

1. Horizontal boring machine
 - a. Table type
 - b. Floor type
 - c. Planer type
 - d. Multiple head type
2. Vertical boring machine
 - a. Vertical turret lathe
 - b. Standard vertical boring machine

- 3. Precision boring machine
- 4. Jig boring machine

Difference between Boring and drilling:-

Drilling	Boring
Drilling operation is performed to originate a hole.	Boring operation is performed to enlarge the hole diameter.
Lip Drilling is the first phase for hole machining. However, sometime centering is done prior to drilling.	Boring is carried out after drilling. Boring cannot be performed if there is no drilled hole or hollow part.
Drill is meant for efficient plunging into the workpiece. So axial length of the hole can be increased by drilling operation.	Plunging is not possible by boring tool. So length of the hole cannot be increased by boring.
Hole diameter is limited to the drill diameter, in fact, they are exactly same.	Boring is performed to increase the hole diameter only.
Cutting tool used in drilling operation is called Drill.	Cutting tool used in boring operation is called Boring tool.
Drill is a multi-point cutter. That means drill has two or more cutting edges that can simultaneously remove material.	Boring bar is a single point cutter, so it has only one main cutting edge that removes material from workpiece.
Chip evacuation is the major problem in drilling. So it cannot be plunged continuously for longer length.	Chip evacuation is not an issue in boring. So it can be fed continuously without any risk of chip clogging.

A taper hole cannot be created by drilling operation. It only makes straight cylindrical holes.

Since boring operation is similar to internal turning, taper holes can be easily created by boring.

(9.3) Broaching:-

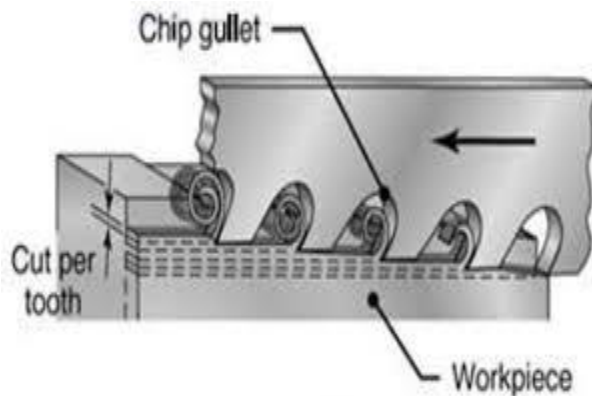

Broaching is a method of removing metal by pushing or pulling a cutting tool called a broach which cuts in fixed path. The tool may be pulled or pushed through the surfaces to be finished. Surfaces finished by Broaching may be flat or contoured and may be either internal or external. Broaching is generally limited to the removal of about 6 mm of stock or less.

Types of Broaching:-

Broaches may be classified in various ways, according to :

1. *Type of operation* : internal or external
2. *Method of operation* : push or pull

3. *Type of construction:* solid, built-up, inserted tooth, progressive cut, rotor cut, double jump, or overlapping tooth.
4. *Function:* surface, keyway, round hole, splint, spiral, burnishing, etc.

Push broach:-

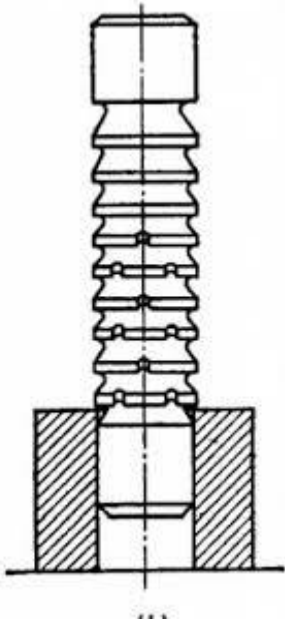

A push broach is one that is designed to be pushed through the workpiece by special press or a push Broaching machine. Because of the tendency to bend under compressive loads, the push broach must be short and stocky, which means fewer teeth are in the broach and , less material can be removed for each pass of the tool. Holes are machined by push broaches only for sizing.

Pull broach:-

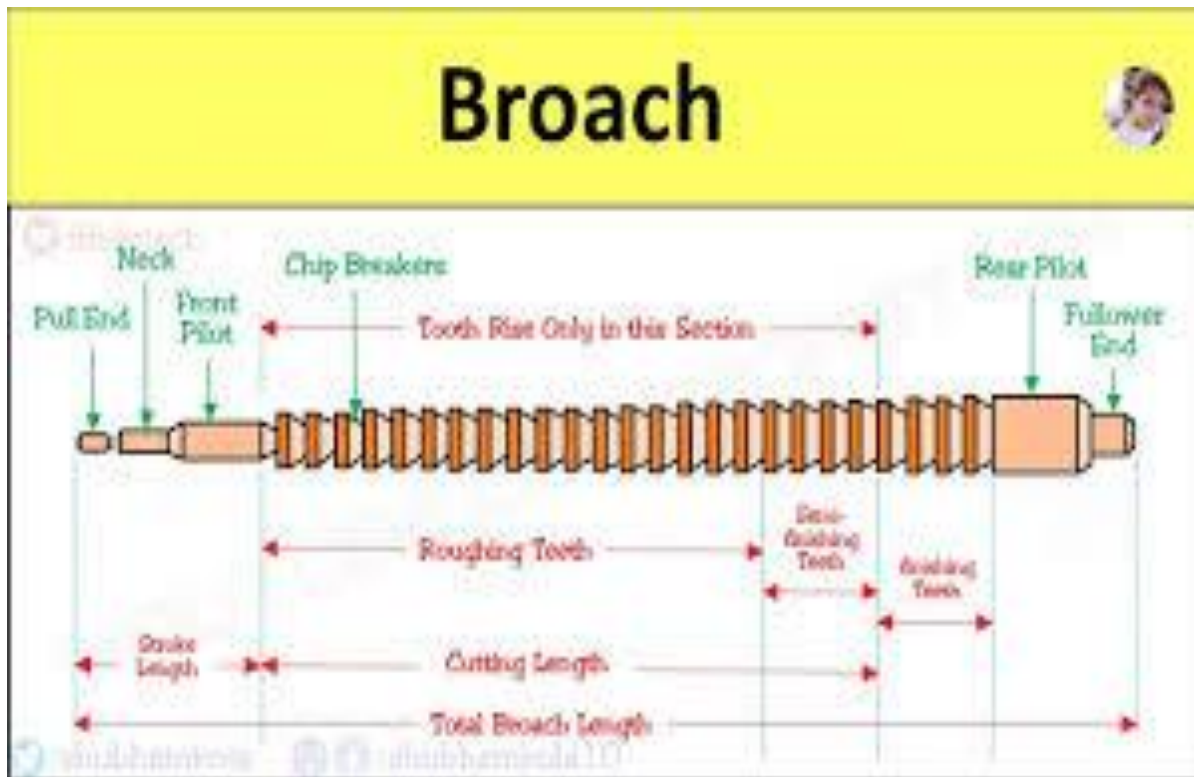

In a pull broach, the tool is entirely in tension and long slender broaches are possible, having a large number of teeth, consequently more stock can be removed for each pass.

Advantages of Broaching:-

1. Rate of production is very high. With properly applied broaches, fixtures, and machines, more pieces can be turned out per hour by Broaching than by any other.
2. Little skill is required to perform a Broaching operation . In most cases the operator merely loads and unloads the workpiece.

3. High accuracy and a high class of surface finish is possible.
4. Both roughing and finishing cuts are completed in one pass of the tool.
5. The process can be used for either internal or external surface finishing.
6. Any form that can be reproduced on a Broaching can be machined.
7. Cutting fluid may be readily applied where it is most effective because a broach tends to draw the fluid into the cut.

Applications of Broaching :-

Broaching operation is used for machining of gears, holes, splines, keyways. They are very economical in the production of irregularly shaped long holes. **Broaching** is used to cutting of grooves and splines in forging as well as in casting.

Possible questions

Short questions:-

1. Define drilling.

Answer:- In a Drilling machine holes may be drilled quickly at a low cost. The hole is generated by the rotating edge of a cutting tool known as the drill which exerts large force on the work clamped on the table.

2. Define boring.

Answer:- The boring is a operation used to enlarge the hole which is previously done by drilling.

3. Define Broaching.

Answer:- It is a method of removing metal by pushing or pulling a cutting tool called broach which cuts in fixed path.

Long questions:-

1. Explain the working of Bench drilling machine with neat sketch.
2. Explain the working of Radial drilling machine with neat sketch.
3. Write the difference between Boring and drilling.
4. Explain push and pull type Broaching .
5. Write the advantages and application of Broaching.

CHAPTER -10

SURFACE FINISH, LAPPING

(10.1) Define surface finish:-

Finishing processes may be employed to: improve appearance, adhesion or wettability, solderability, corrosion resistance, tarnish resistance, chemical resistance, wear resistance, hardness, modify electrical conductivity, remove burrs and other surface flaws, and control the surface friction.

In a manufacturing plant, a product may be shaped , turned, milled or drilled, and left in that condition as being satisfactory for use. However, if a better finish is desired , for looks, for accuracy, for wearing qualities, or for any other reasons, one of the microfinishes that include lapping, honing, superfinishing, polishing, buffing, may be employed. In some cases other operations are done only to get durable finishes.

(10.2) Lapping:-

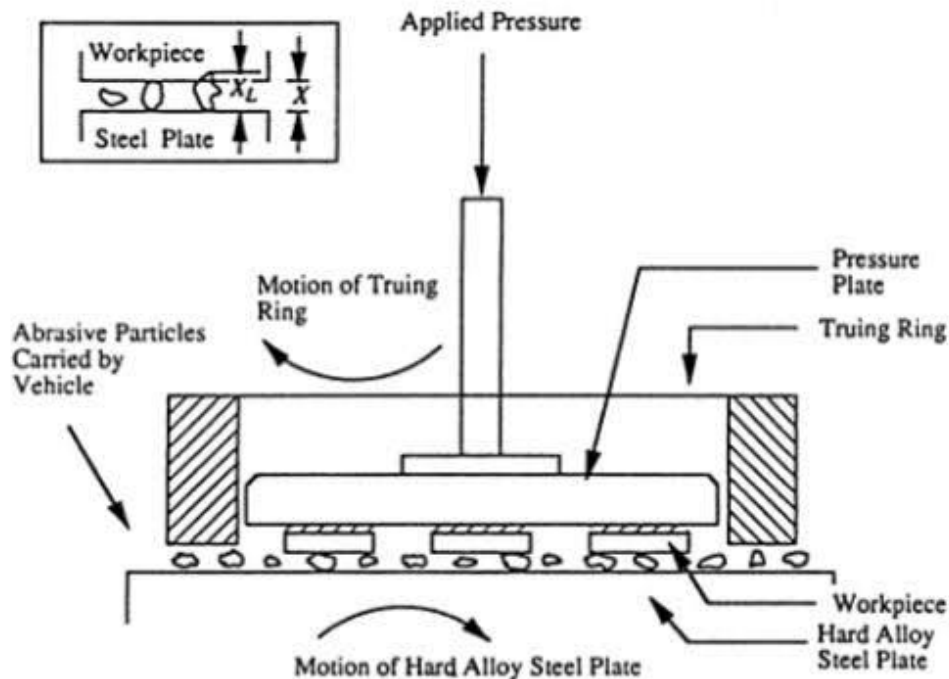

37

- Lapping is an abrading process that is used to produce geometrically true surfaces, correct minor surface imperfections, improve dimensional accuracy, or provide a very close fit between two contact surfaces.
- Very thin layers of metal (0.005 to 0.01 mm) are removed in lapping and it is, therefore, evident that lapping is unable to correct substantial errors in the form and sizes of surfaces, and surface finish cannot be obtained by other methods.

- Abrasive powders such as emery, corundum, iron oxide, chromium oxide, etc. Mixed with oil or special pastes with some carrier are used in lapping.
- Most lapping is done by means of lapping shoes or quills, called laps, that are rubbed against work.
- The face of a lap becomes charged with abrasive particles. Charging a lap means to embed the abrasive grains into its surface.
- Laps may be made of soft cast iron, brass, copper, lead or soft steel.
- Cylindrical work may be lapped by rotating the work in lathe or drill press and reciprocating the lap over the work in an ever changing path.
- Small flat surfaces may be lapped by holding the work against a rotating dish, or the work may be moved by hand in an irregular path over a stationary faceplate lap.
- In equalizing lapping the work and lap mutually improve each other's surface as slide on each other.

(10.3) Specific cutting in lapping:-

The various operations in lapping are:

1. Honing:-

- Honing is grinding or a abrading process mostly for finishing round holes by means of bonded abrasive stones, called homes.

- Honing is therefore a cutting operation and has been used to remove as much as 3mm of stock but is normally confined to amounts less than 0.2mm.
- So honing is primarily used to correct some out of roundness, taper, tool marks, and axial distortion.
- Honing stones are made from common abrasive and bonding materials, often impregnated with sulphur, resin, or wax to improve cutting action and lengthen tool life.
- Material honed range from plastics, silver, aluminium, brass, and cast iron to hard steel and cemented carbides.

2. Superfinishing:-

- Superfinishing is an operation using bonded abrasive stones in a particular way to produce an extremely high quality of surface finish in conjunction with an almost complete absence of defects in the surface layer.
- A very thin layer of metal (0.005 to 0.02mm) is removed in superfinishing.
- This operation may be applied for external and internal surfaces of parts made of steel, cast iron and non ferrous alloys, which have been previously ground or precision turned.
- It is most frequently used to obtain very fine surface finish.

3. Polishing:-

- Polishing is a surface finishing operation performed by a polishing wheel for the purpose of removing appreciable metal to take out scratches, tool marks, pits and other defects from rough surfaces.
- In polishing, usually accuracy of size and shape of the finished surface is not important, but sometimes tolerance of 0.025mm or less can be obtained in machine polishing.
- Polishing wheels are made of leather, papers, canvas, felt, or wool.

4. Power brushing:-

- High speed revolving brushes can be used to remove burrs, fins, sharp edges or minute surface defects from manufactured components. Tough fiber wheels, wire bristle and Tampico are utilized to produce power brushes. These materials are flexible and can conform to irregular surfaces.

5. Tumbling:-

Tumbling, often, is the least expensive process for removing rust and scale from metal parts.

The operation is accomplished by placing workpieces in a drum or barrel, together with stars, jacks, slugs, or abrasive materials. The abrasive materials can be sand, granite chips, slag, or aluminium oxide pellets. In

operation, the barrel is rotated, and the movement of the workpiece and the accompanying slugs or abrasive materials against each other produces by friction a fine action which remove the fins, flashes, and scale from the product.

6. Pickling and oxidizing:-

Pickling refers to the removal of surface oxides and scale from metals by acid solutions.

Common pickling solutions contain sulphuric or hydrochloric acids and water and sometimes inhibitors which have been developed to reduce the harmful action of the acid fumes on plant equipment.

In pickling, the parts must be rinsed and completely neutralized by an alkaline rinse, otherwise any trace of acid will corrode the material and harm paint or other subsequent coating.

Pickling is commonly done on rolled shapes, wires, sheets, heat treated steel parts, wrought and cast aluminium parts. In some applications, such as on aluminium, pickling is called oxidizing.

Possible questions

Short questions:-

1. Define lapping.

Answer:- Lapping is an abrading process that is used to produce geometrically true surfaces, correct minor surface imperfections, improve dimensional accuracy, or provide a very close fit between two contact surfaces.

2. Define honing.

Answer:- Honing is a grinding process mostly for finishing round holes by means of bonded abrasive stones.

3. Define superfinishing.

Answer:- Superfinishing is an operation using bonded abrasive stones in a particular way to produce an extremely high quality of surface finish in conjunction with an almost complete absence of defects in the surface layer.

Long questions:-

1. Briefly explain the process of lapping.

2. Explain honing and superfinishing.

3. Write short notes on

a. Polishing

b. Pickling and oxidizing

c. Power brushing

